



REKLUSE[®]
RADIUS_x

REKLUSE MOTOR SPORTS

INSTALLATION GUIDE

Doc ID 191-6302
Revision 112917

OVERVIEW

- Read the separate included Safety Information document before operating the vehicle with the product installed.
- If you are performing the installation of this product for a customer or another person, instruct them to read the Safety Information document and the Installation and User Guide before operating the vehicle with the product.
- Read this entire document before performing any steps, so you will know what to expect.
- When reinstalling components, use the torque specifications found in your service manual. Torque values listed are valid as of the date shown in the document revision number above.
- Use clean, quality JASO MA or JASO MA2 certified oil

All (Original Equipment) components will be reused except:

- This kit will replace all of the friction disks and drive plates with a Rekluse clutch pack.
- Inspection of components is necessary during installation
- This kit will replace the slave cylinder with a Rekluse adjustable slave cylinder which allows for adjusting the installed gap in the clutch pack.

INSIDE THIS DOCUMENT

- INSTALLATION TIPS
- TOOLS NEEDED
- INCLUDED PARTS
- INSTALLATION INSTRUCTIONS
 - CLUTCH DISASSEMBLY AND INSTALLATION
 - SLAVE CYLINDER DISASSEMBLY AND INSTALLATION
 - SETTING THE INSTALLED GAP
 - CHECKING FREE PLAY GAIN
 - FREE PLAY GAIN TROUBLESHOOTING
 - BREAK-IN PROCEDURE
- MAINTENANCE
- TROUBLESHOOTING GUIDE
 - FREE PLAY GAIN TROUBLESHOOTING
 - OPTIMIZING EXP ENGAGEMENT

INSTALLATION TIPS

- Protect eyes and skin – wear safety glasses and thin disposable work gloves.

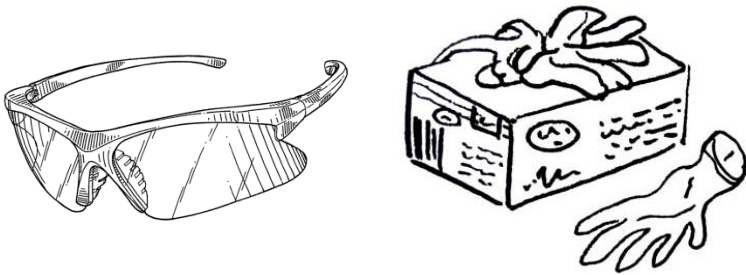

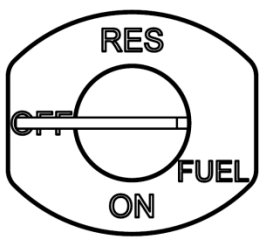

- Work in a ventilated area.
- If the motorcycle is a two stroke turn the fuel petcock to “OFF.”



- During disassembly and installation lay the bike on its left side to avoid draining the oil. Do this by placing the handle bar on a center stand. Catch fuel that may drain from vent tubes.



TOOLS NEEDED

	 8 mm	 4mm		
Hydraulic Clutch Fluid	8mm socket	4mm Allen	Torque wrench	Metric End Wrench Set
		 T25	 T20	
Dental Pick	No Tools Required	Torx Bit T25	Torx Bit T20	

INCLUDED PARTS

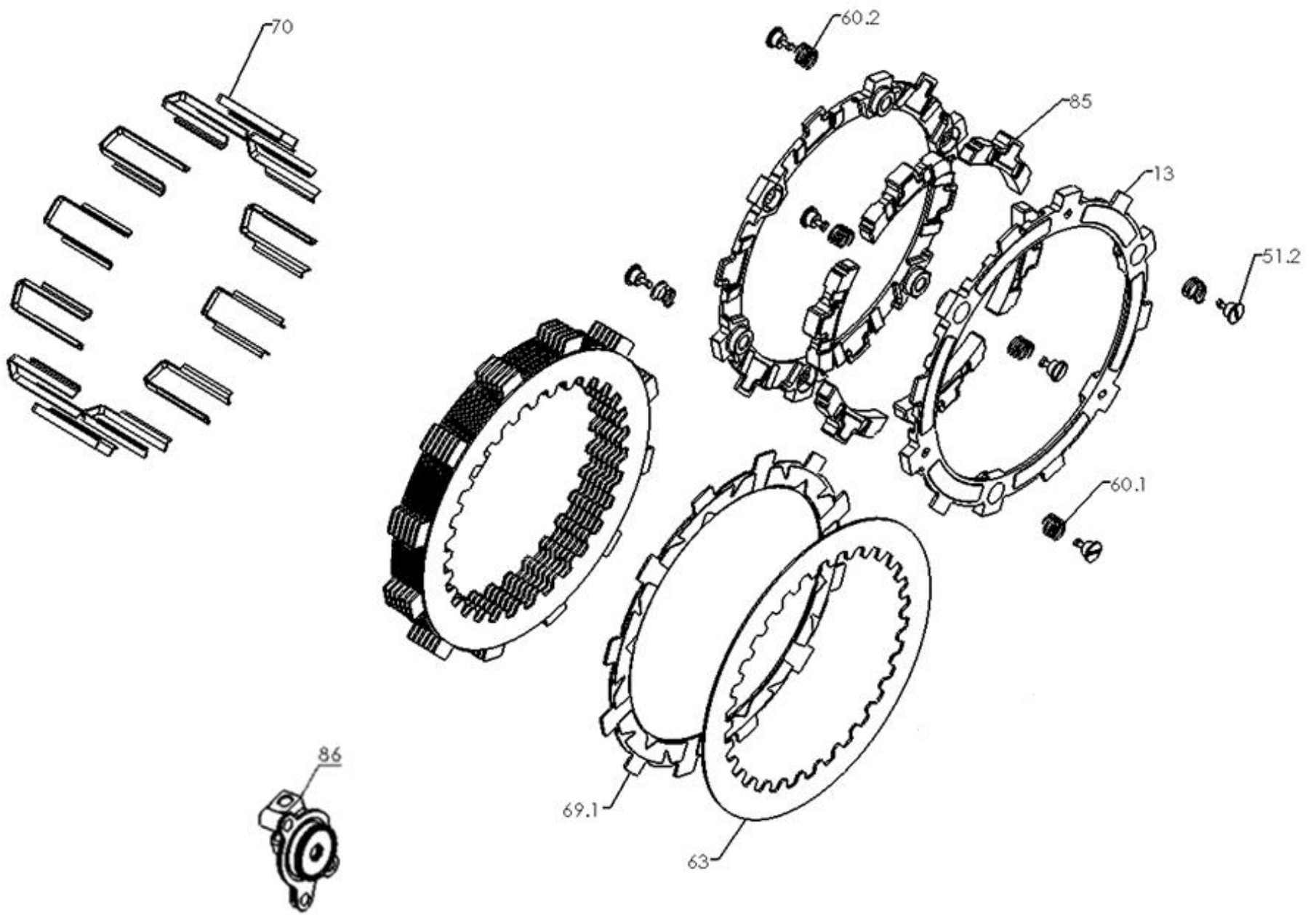

Item	Description	Qty.
13	EXP Base	2
51.2	Quarter Turn Pin	6
60.1	EXP Spring	3
60.2	EXP Spring	3
70	Basket Sleeve	12
63	Drive Plate	**
69.1	TorqDrive® Friction Disk	**
85	Wedge Assembly	1
86	Adjustable Slave Cylinder	1
Not Shown	Spacing Gasket	**
Not Shown	Orange FPG Rubber Band	1
Not Shown	EXP Spares	6
Not Shown	Quarter Turn Pin Spares	2
<p>**See the model-specific CLUTCH SETUP SHEET for correct part quantity and configuration.</p>		

INSTALLATION INSTRUCTIONS

CLUTCH DISASSEMBLY AND INSTALLATION

1. Soak the EXP disk and Torqdrive friction disks in engine oil for at least 5 minutes.

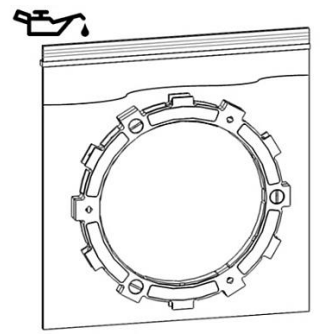

2. If your bike is carbureted, turn the fuel petcock to "OFF" and lay the bike on its left side.

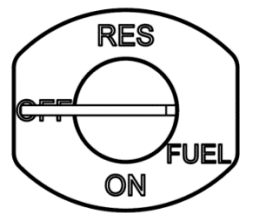

3. Remove the clutch cover



8 mm



NOTICE

Take note of each clutch cover bolts specific location as length can vary between them. Failure to replace these bolts in the proper location after clutch installation can result in damage to your motorcycle.

4. Remove the pressure plate screws along with the springs and pressure plate assembly.

NOTICE

Throw-out washers can stick to the back of the pressure plate. Be sure to reindex any throw-out washers back onto the throw-out.

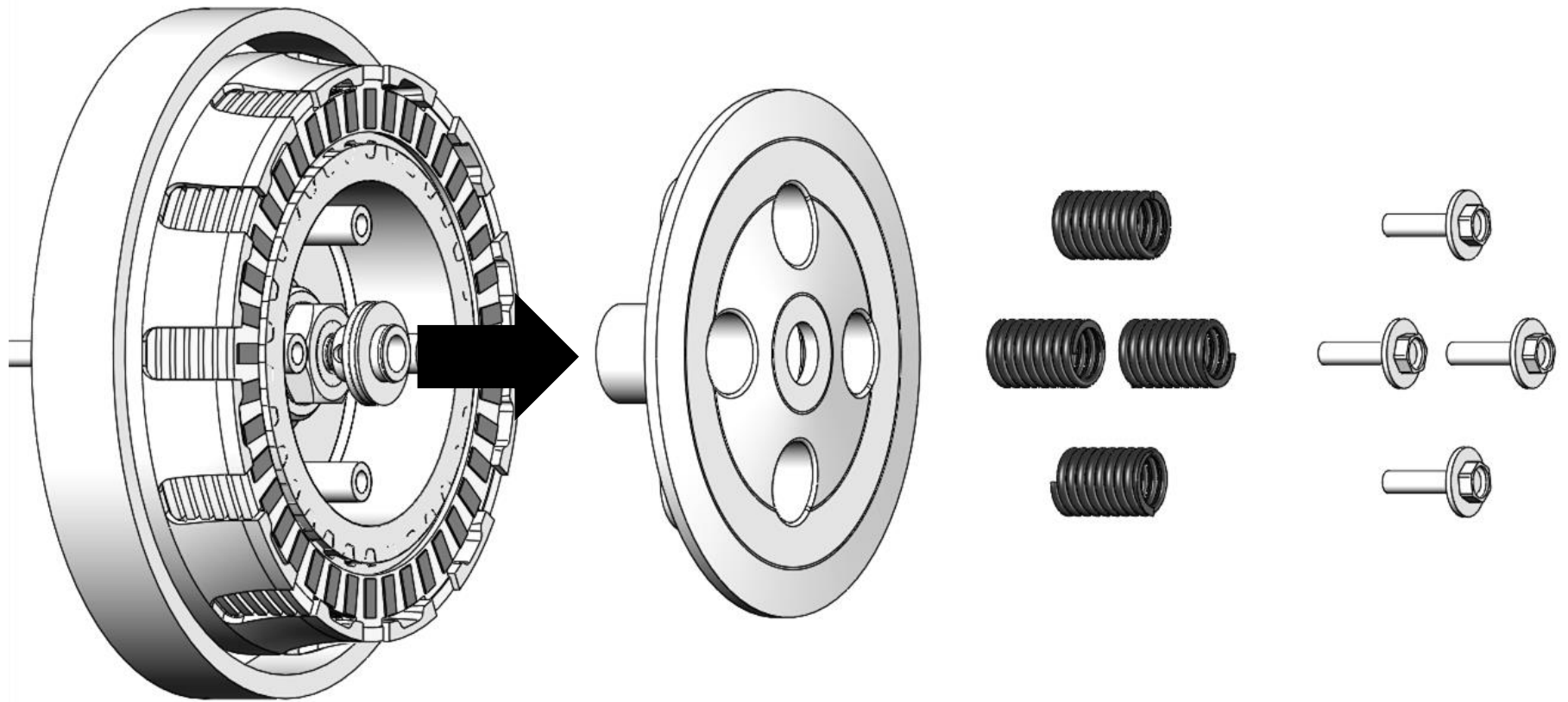

5. Remove and set aside the OE clutch pack. (All Plates)

NOTICE

Some models have a clutch boss spring located in the bottom of the OE friction pack. This consists of a spring, seat and narrow friction (shown below). If your bike is equipped with these parts remove them.

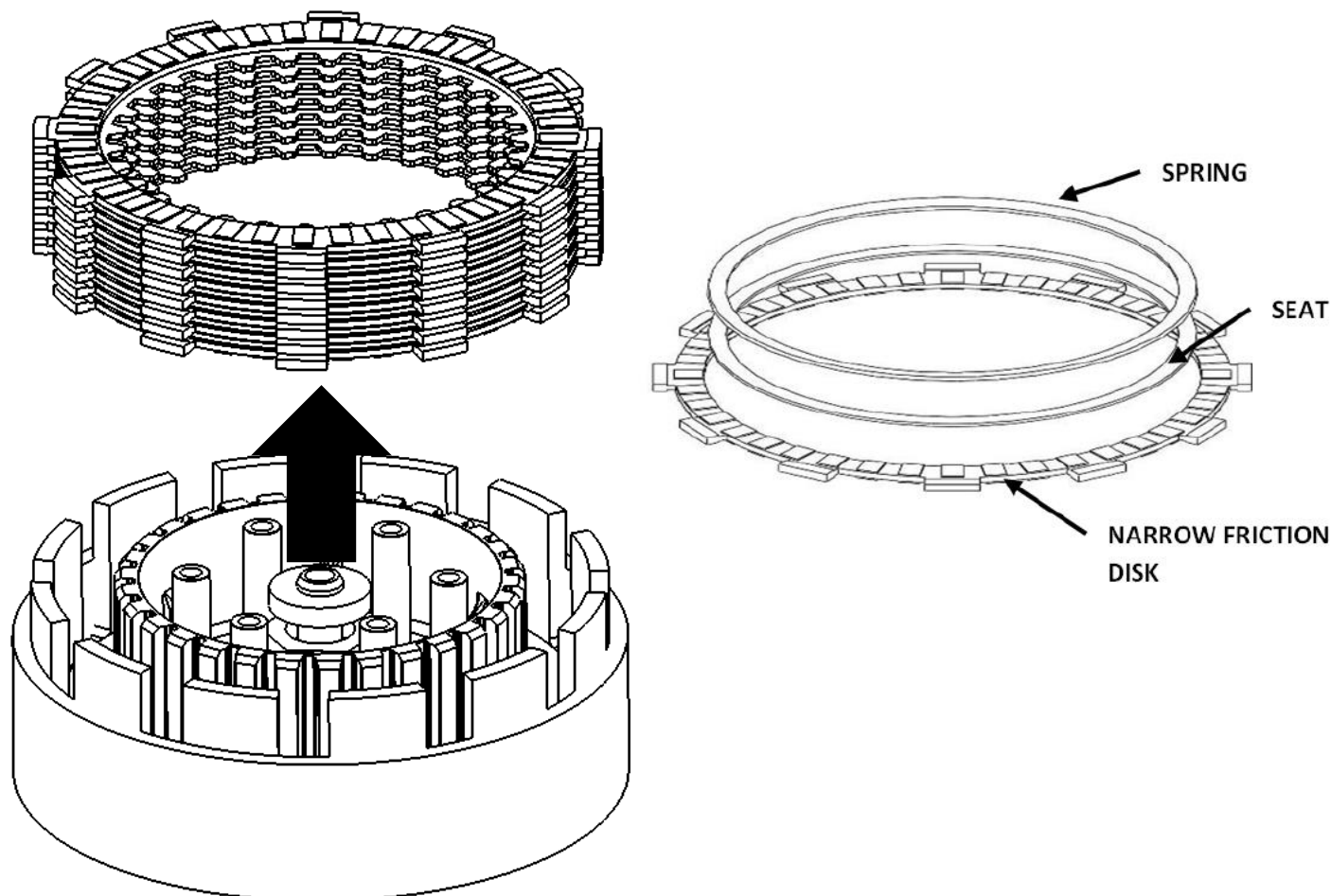

6. Inspect the basket for cushion slop or notching. If notched or worn, it is recommended to replace the basket. See Read Me First for more inspection information. **Do not install sleeves or use product with a notched basket.**

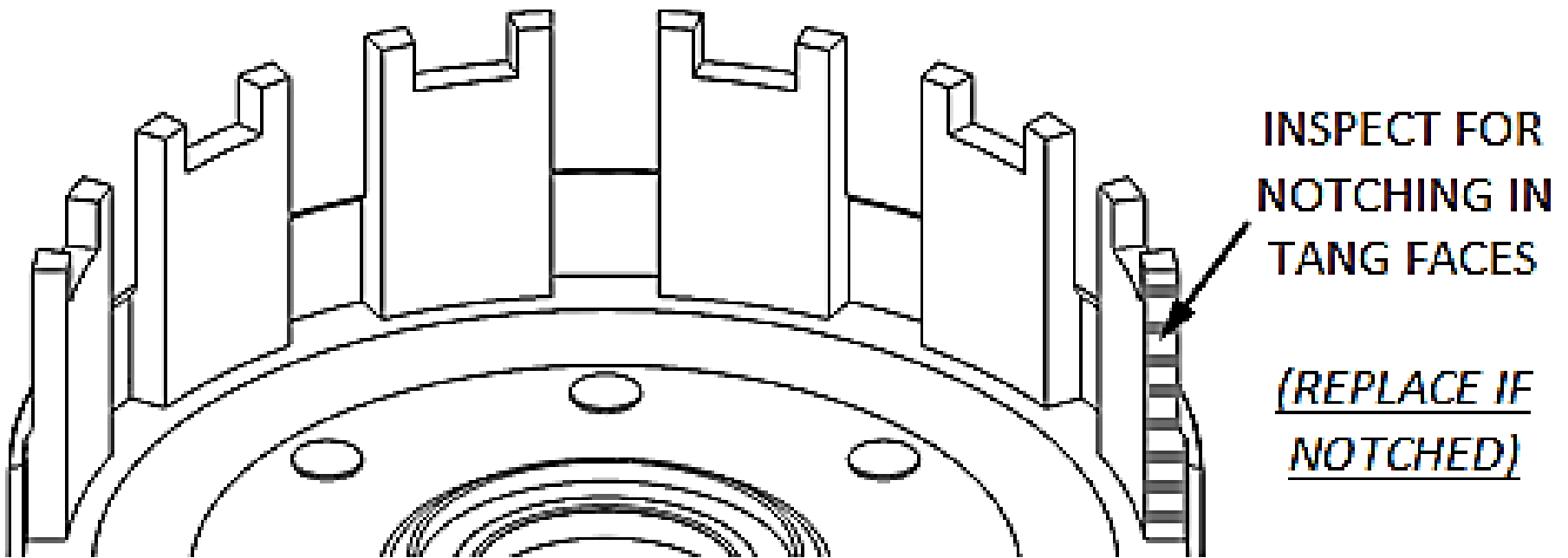

⚠ WARNING

Failure to inspect the basket and replace if necessary could result in death, serious injury, and/or property damage.



REKLUSE®
clutchbasket



NOTICE

If the basket is notched or worn, Rekluse recommends replacing it with a Rekluse Billet Clutch Basket (available for most models).

7. Inspect your OE center hub and pressure plate flanges for excess wear. If wear is visible use a drop gauge to verify that the wear across the flange does not exceed .005" (.12mm).

Flange wear groove depth should not exceed .005"

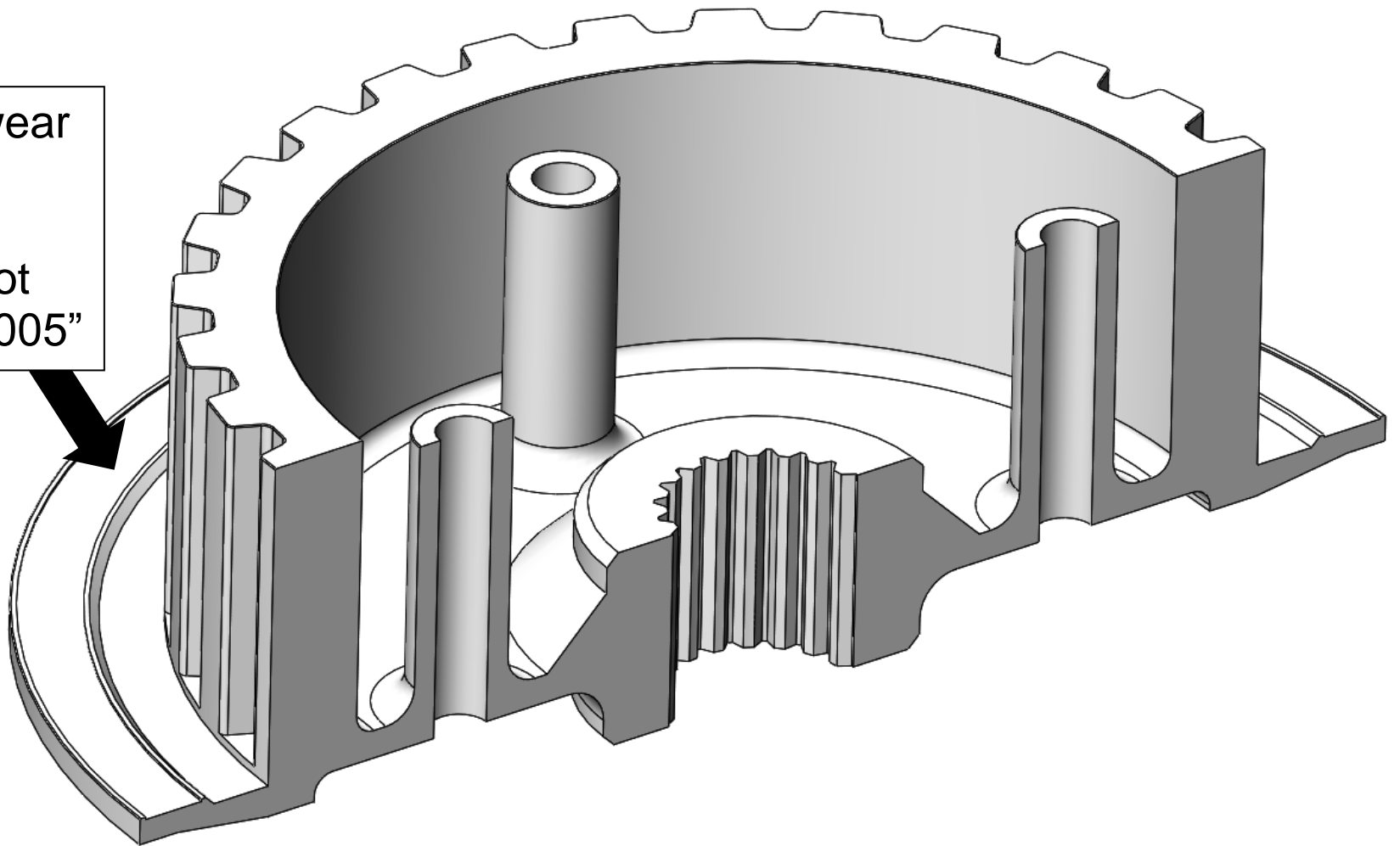

Flange wear groove depth should not exceed .005"

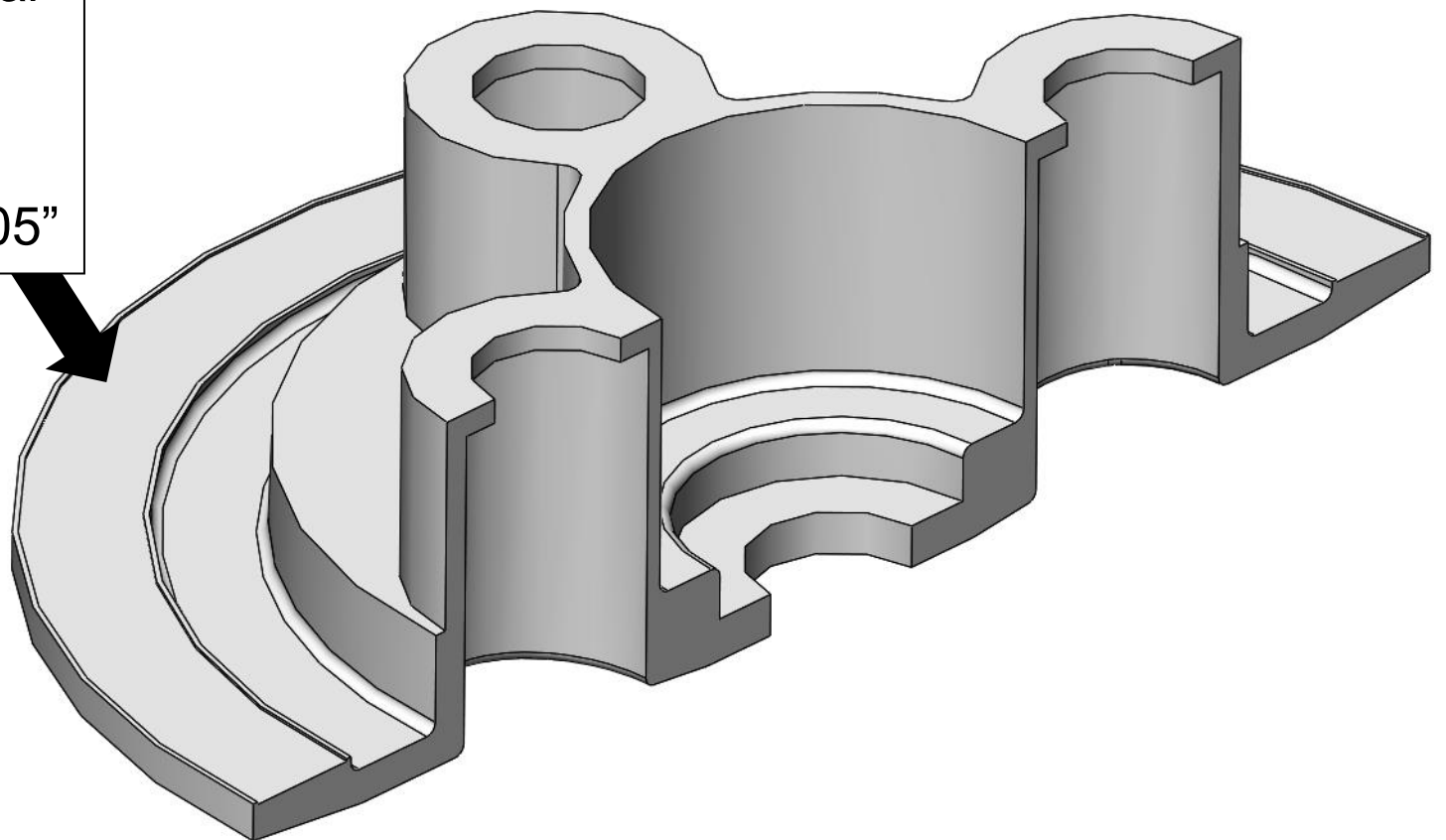

⚠ WARNING

Failure to inspect the pressure plate and center hub and replace if necessary could result in death, serious injury, and/or property damage.

8. Install the [#70] Rekluse basket sleeves in the orientation shown making sure they are seated in the basket slots.

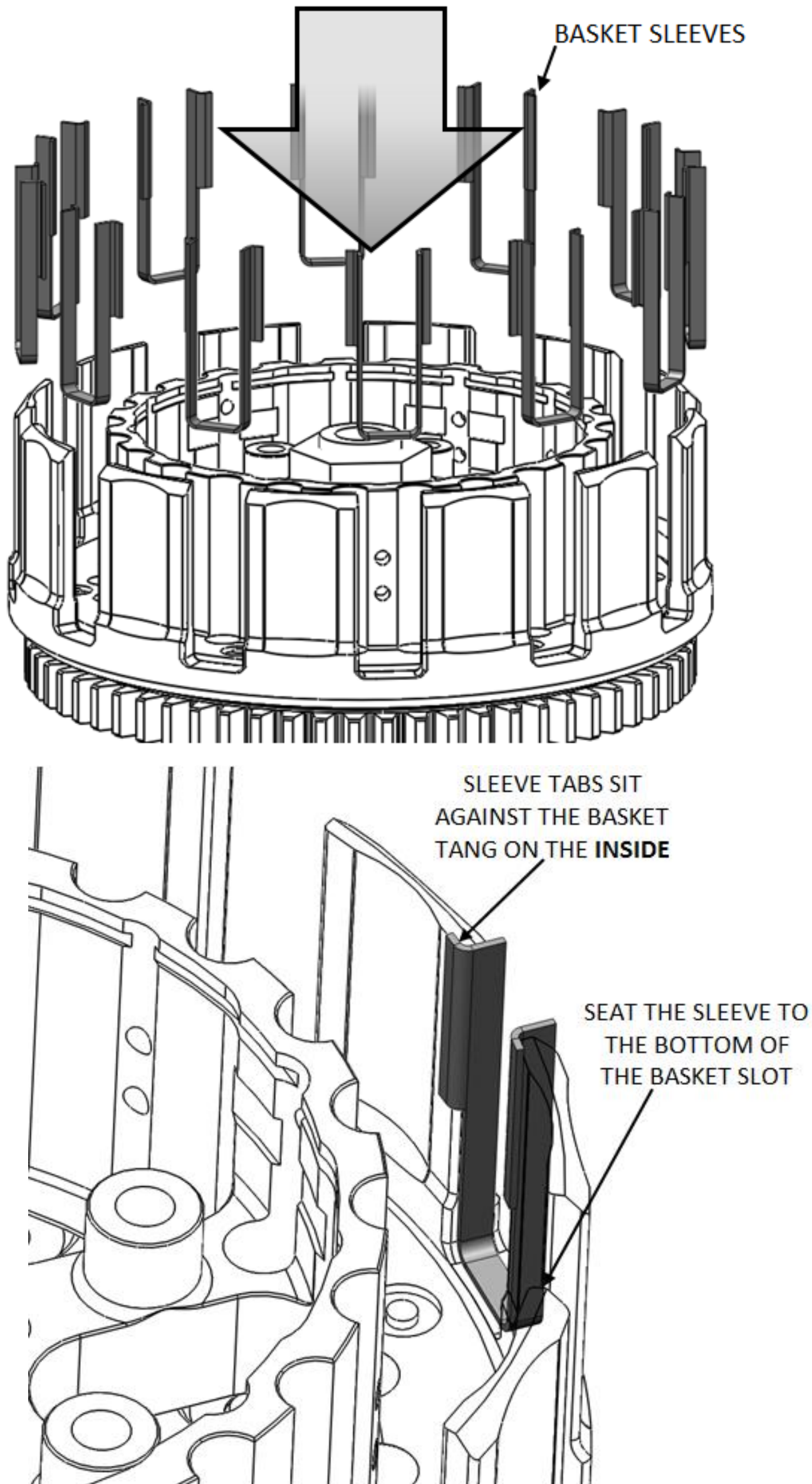

NOTICE

When seated in the basket the sleeves may stick above or below the top of the basket.

9. Install the Rekluse clutch pack. **See setup sheet for proper clutch pack configuration as they vary depending on bike model.**

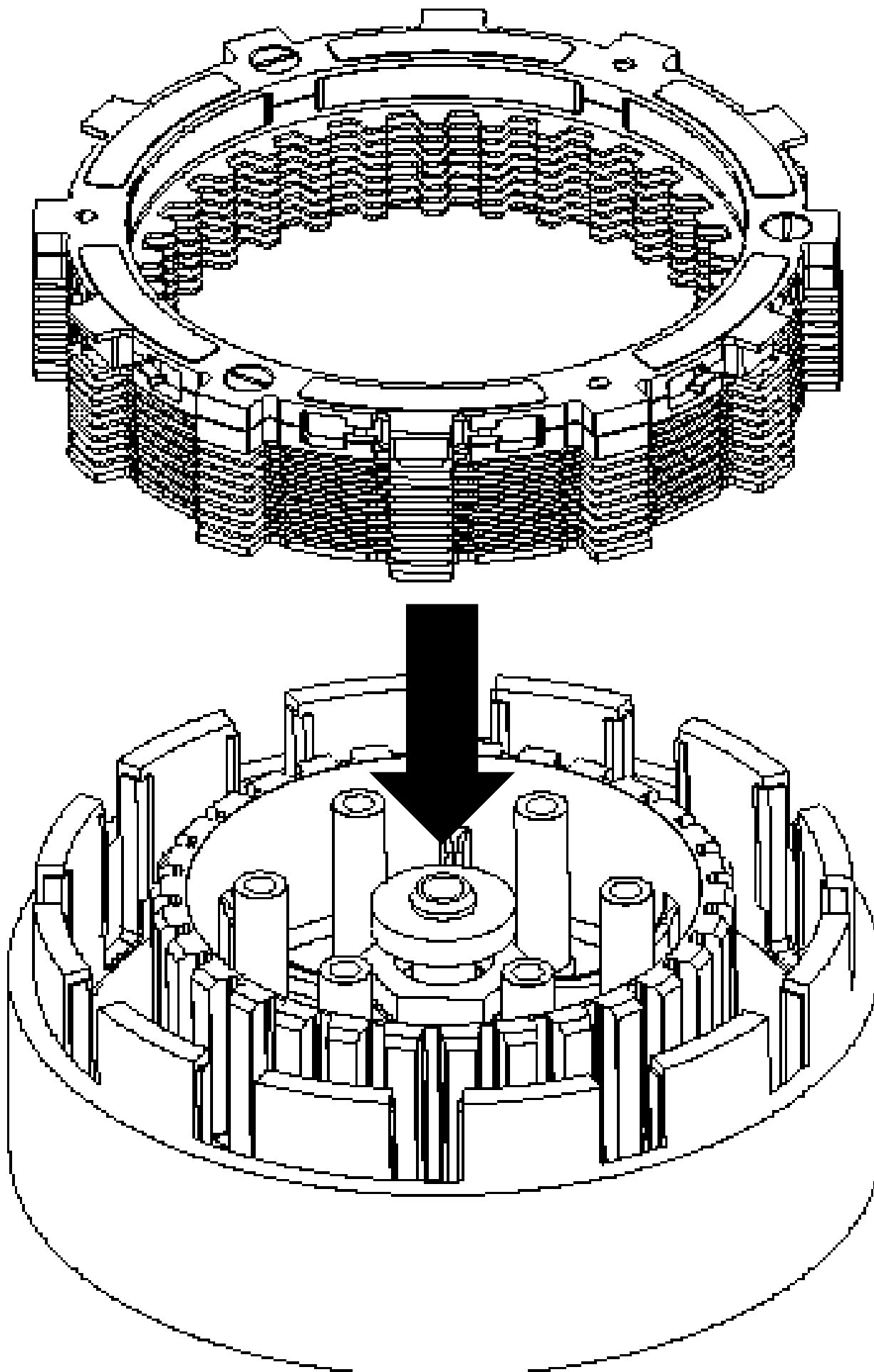

10. Reinstall your OE pressure plate followed by the provided pressure plate springs, using the OE pressure plate bolts. Torque bolts to OE specification.

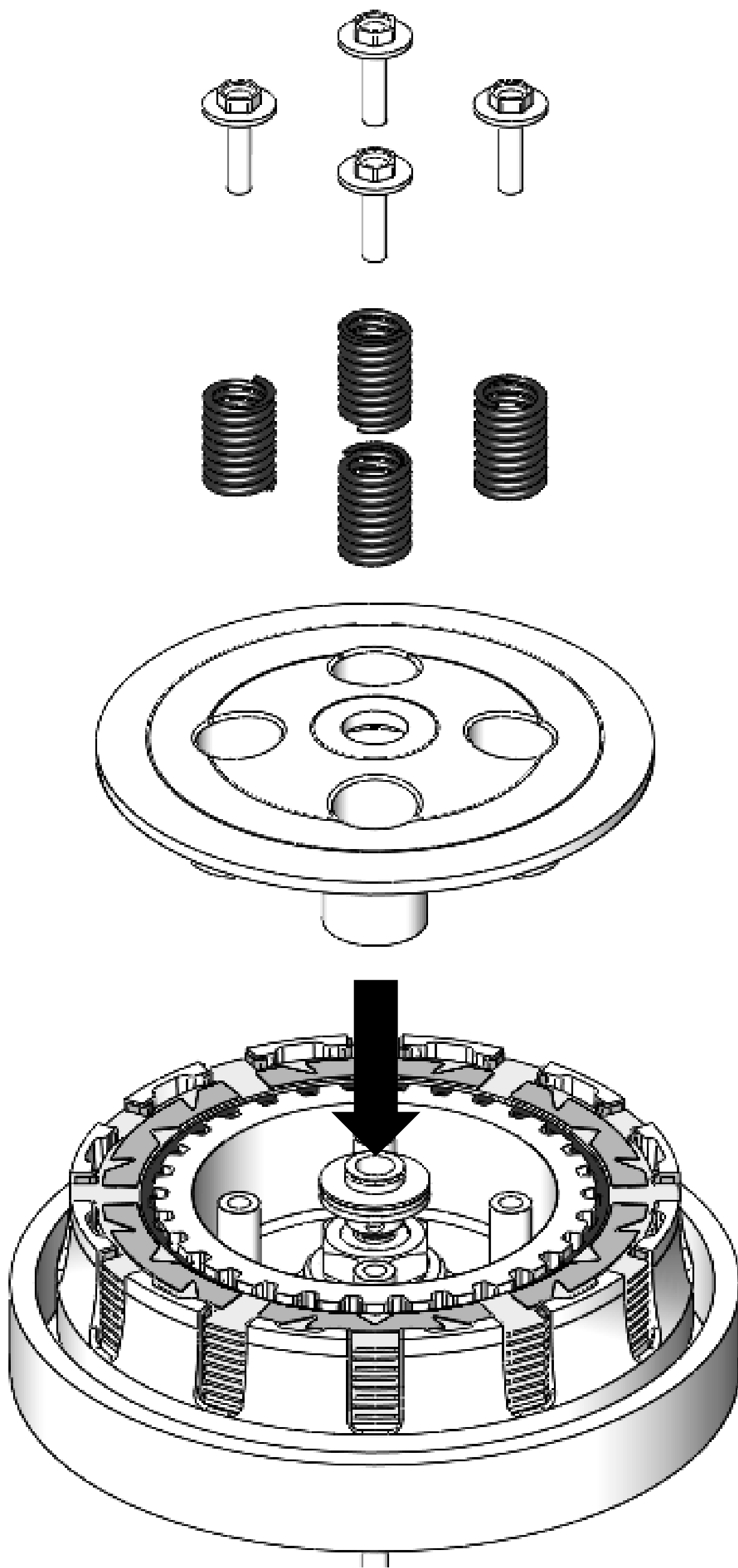

11. Reinstall your OE clutch cover by lightly tightening the cover bolts in small increments in a star pattern. Torque the cover bolts to specification.

NOTICE

Most models require a clutch cover spacing gasket to achieve adequate clearance inside the clutch to the basket sleeves. If your kit includes a spacing gasket (see setup sheet to learn if it does), install it in place of the OE gasket.



8 mm

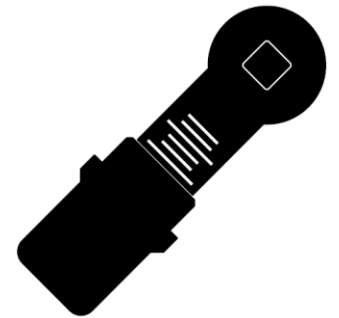
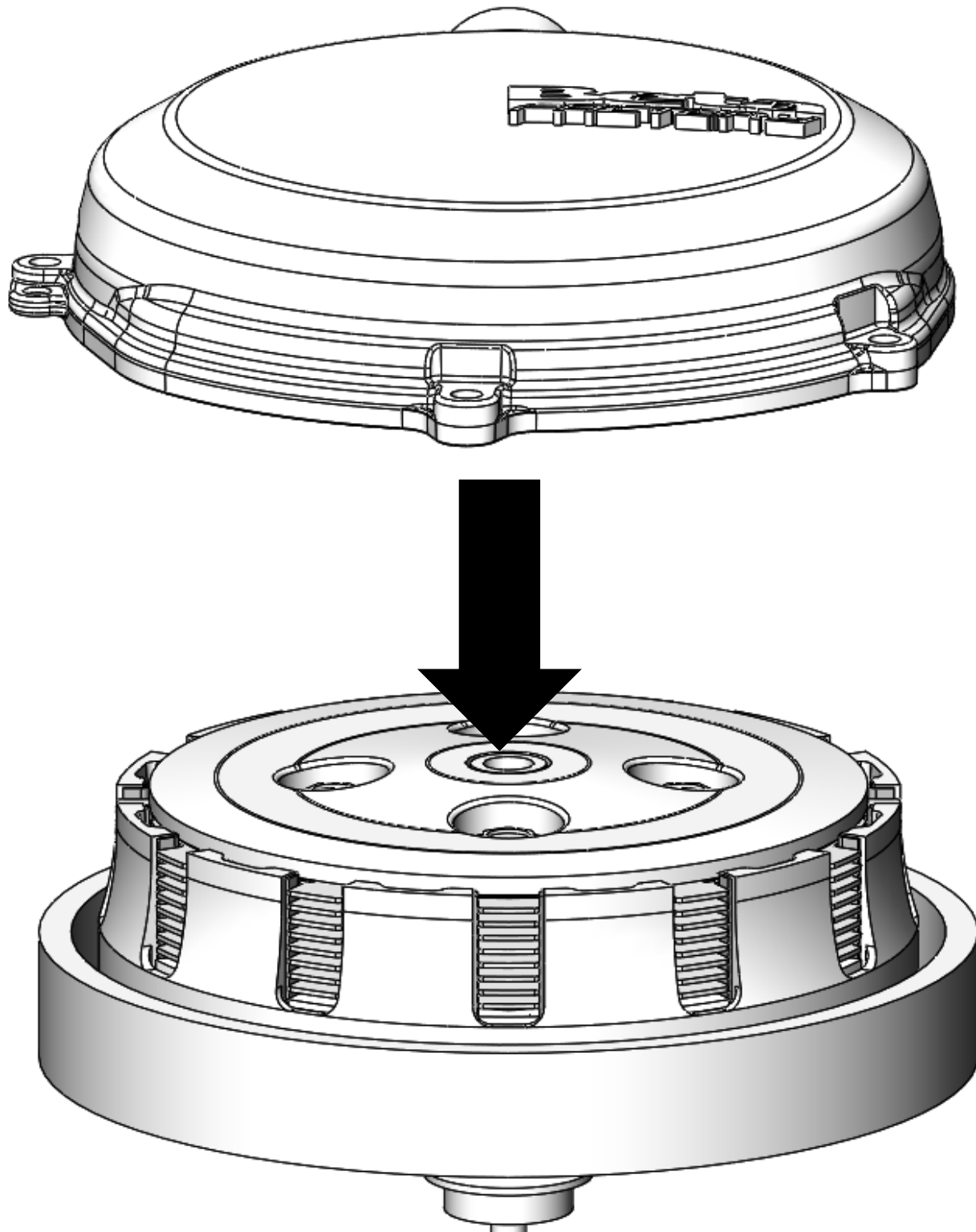

SLAVE CYLINDER INSTALLATION

Slave cylinder housings appear different from one bike model to the next, and may have one fluid port or two. Single-port slave housings will reuse the OE banjo bolt with its integrated bleeder screw, while double-port slave housings will include a separate bleeder screw and will reuse the OE banjo bolt. The bleeding process will be the same for either type.

NOTICE

For GasGas and Beta motorcycles:

See the CLUTCH SETUP SHEET for additional instructions regarding the slave cylinder installation, as special requirements are necessary for your bike model.

Handle with care! During assembly there is a small ball bearing installed in the slave piston with a small amount of grease. When installing the Rekluse slave cylinder, make sure the ball does not come loose.

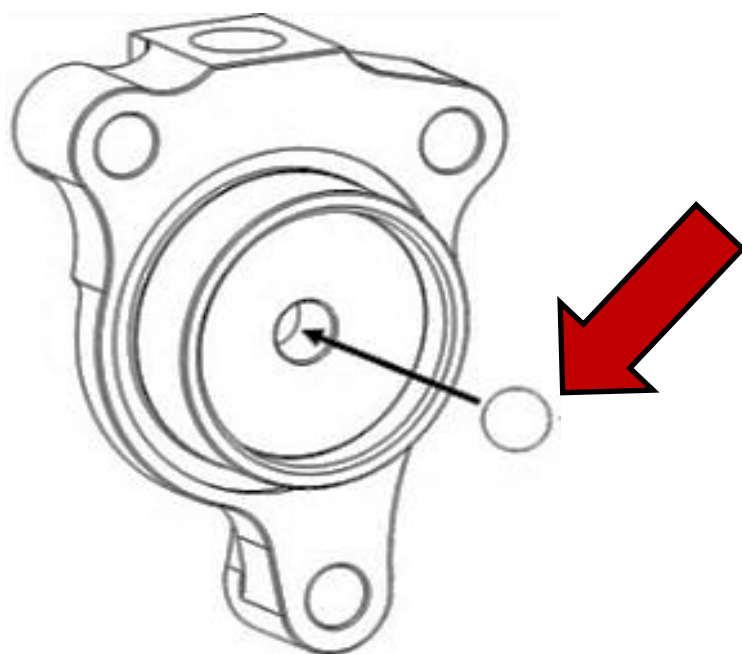

12. Stand the bike up and lean it on its kickstand or place it on a suitable bike stand.

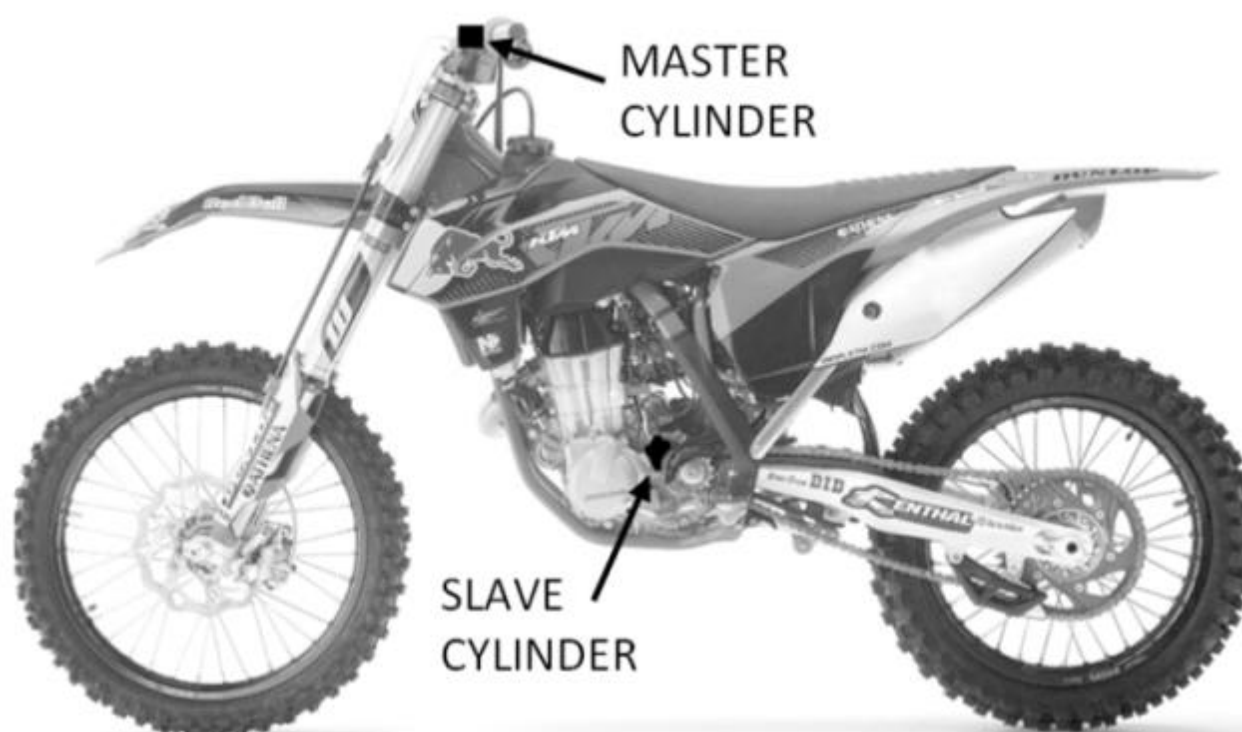

13. On a workbench (away from the engine), bleed the Rekluse slave cylinder by this procedure:

a. Use a 4mm Allen key to make the top O-Ring visible on the adjuster screw.

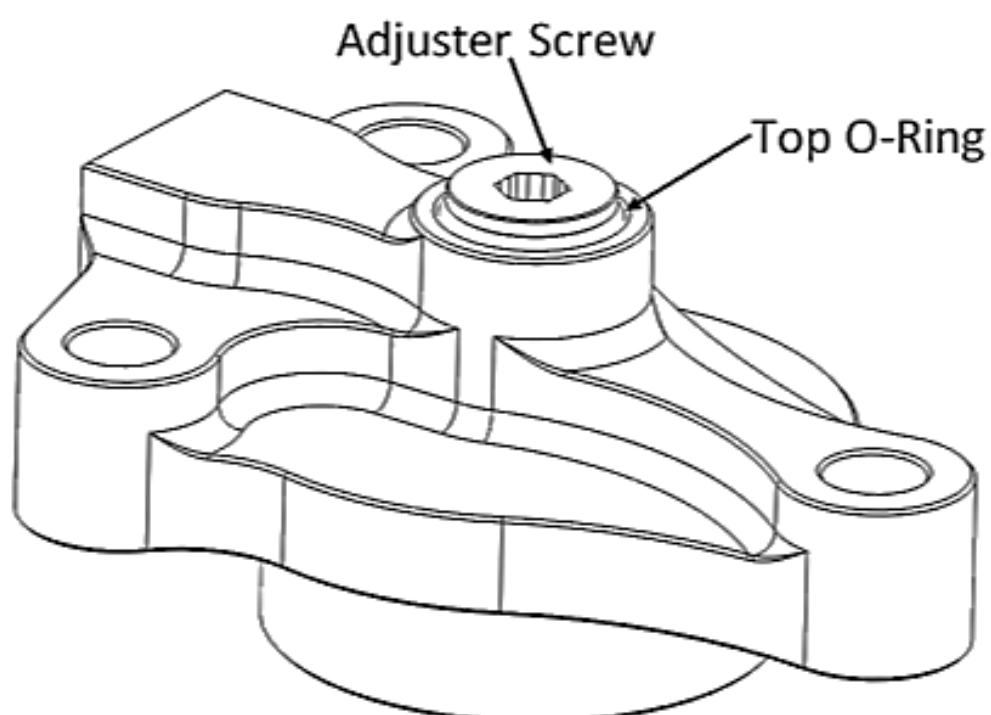

b. Compress the piston until it bottoms.

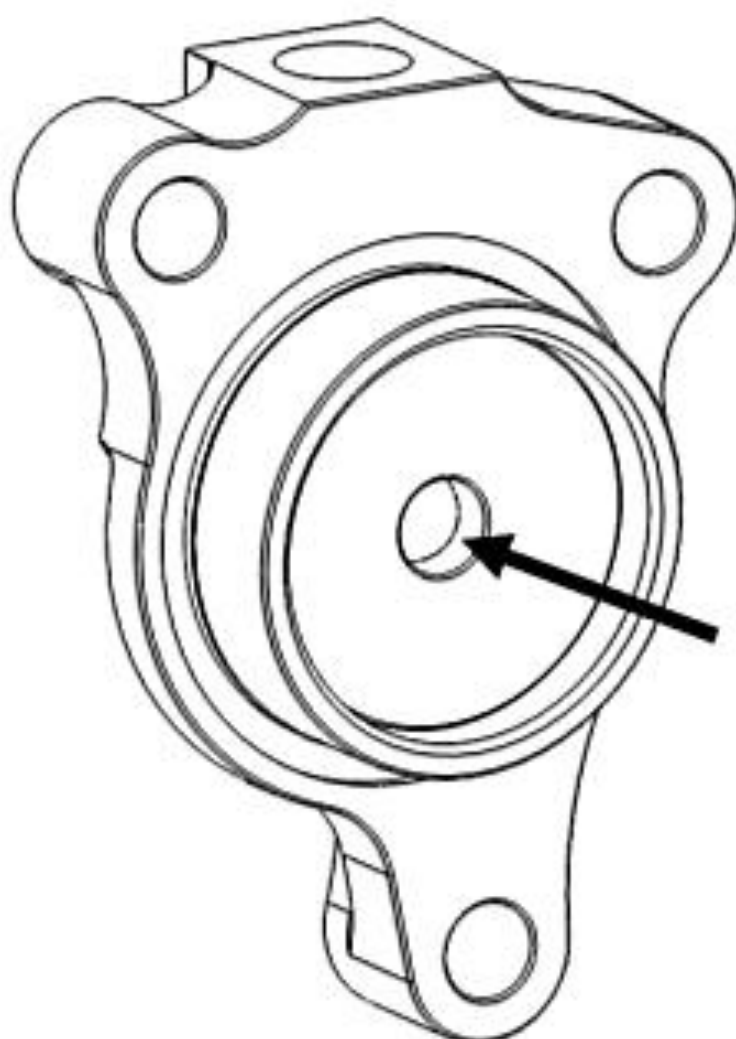

⚠ WARNING

Be sure to use the correct clutch fluid! Check the cap of the clutch master cylinder to determine which clutch fluid to use. Failure to use the correct fluid will result in seal damage and/or failure.

c. Pour clutch fluid into the slave cylinder port.

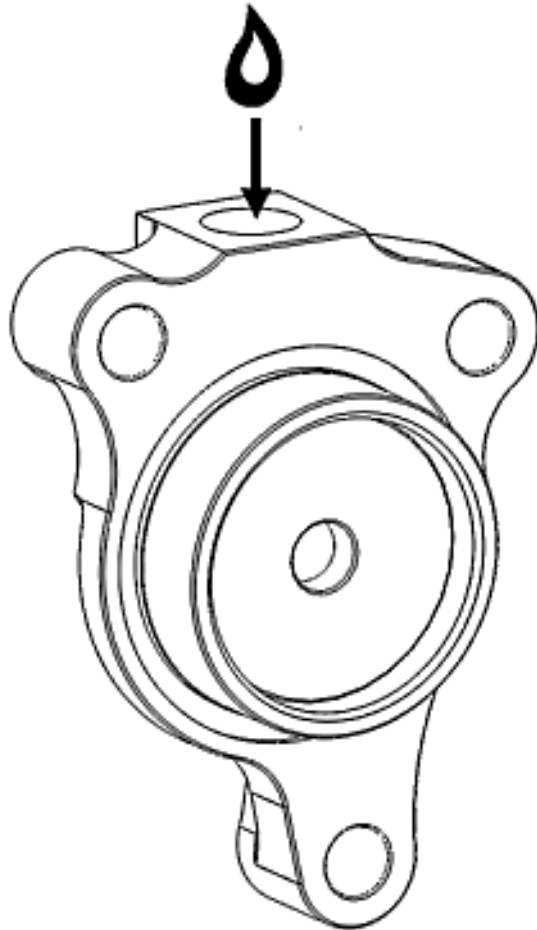

d. Turn the adjuster screw clockwise until it bottoms, keeping the fluid topped off.

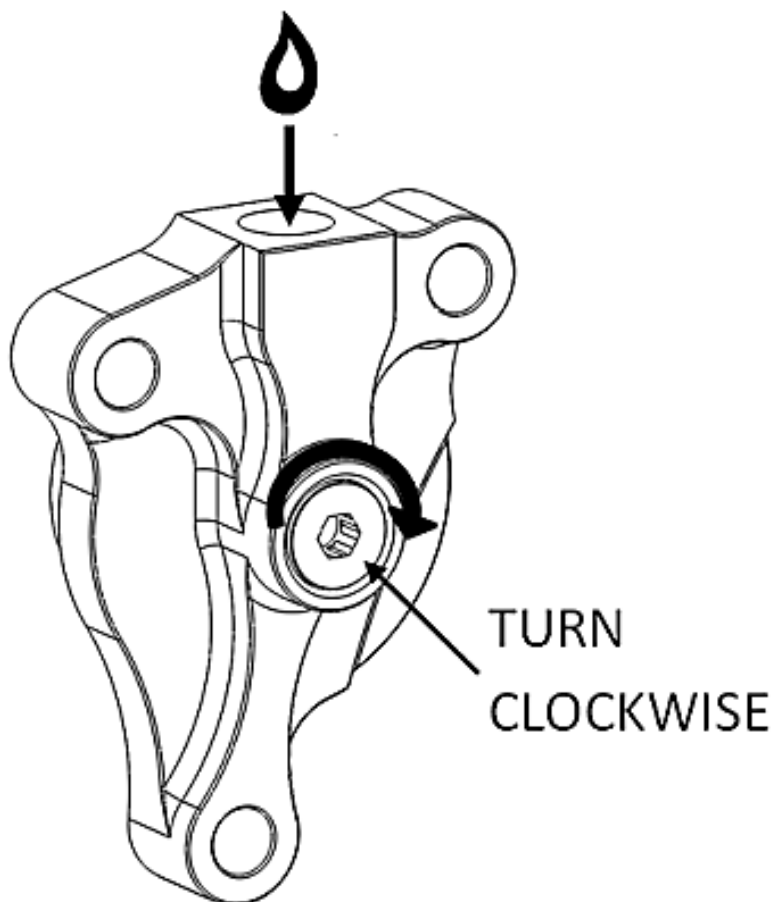

e. Turn the adjuster screw back to the initial position with the top O-ring visible.

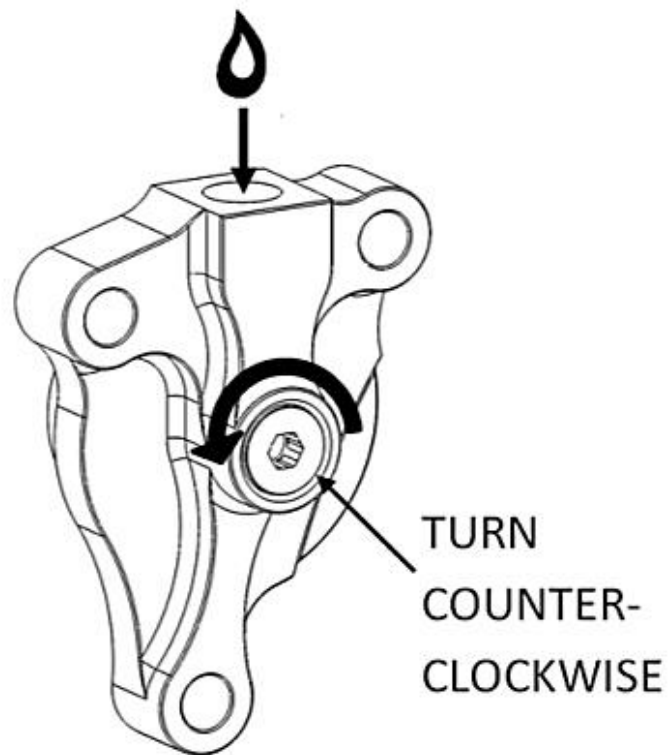

f. Compress the piston until it bottoms out. Repeat the process until there is no longer air escaping from the top port when the piston is compressed.

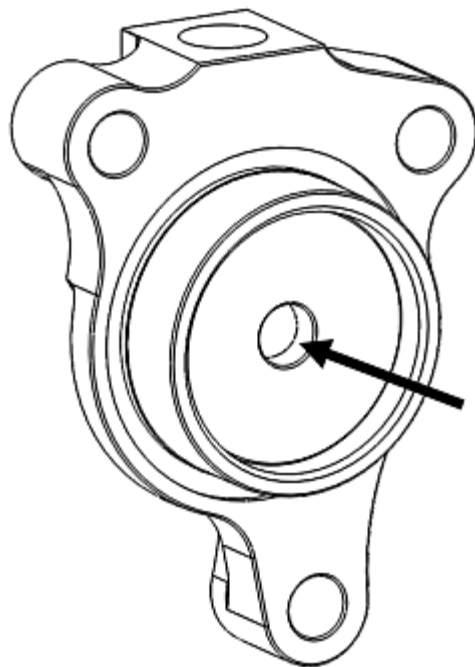

NOTICE

When compressing the piston, fluid can shoot out from the slave cylinder port. Be sure to wear eye protection.

14. Check that the ball bearing is still in place.

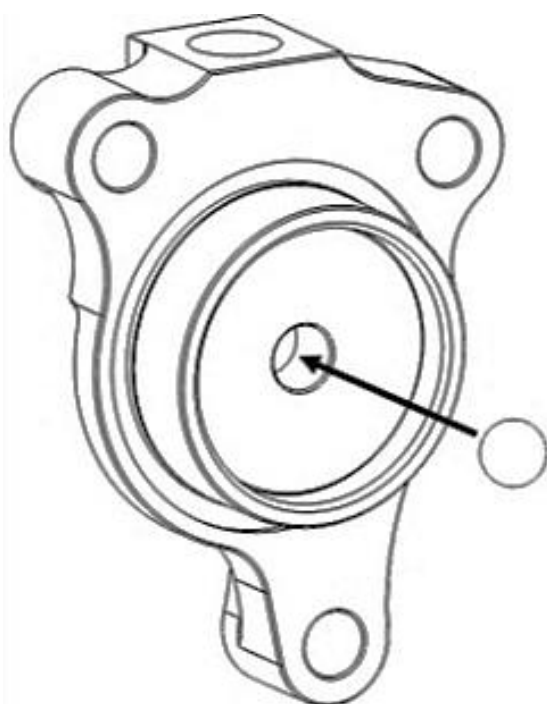

NOTICE

The Rekluse slave cylinder comes preassembled in the kit. If the parts become separated, assemble them in the following order: Rekluse slave cylinder, O-ring, then the supplied paper gasket.

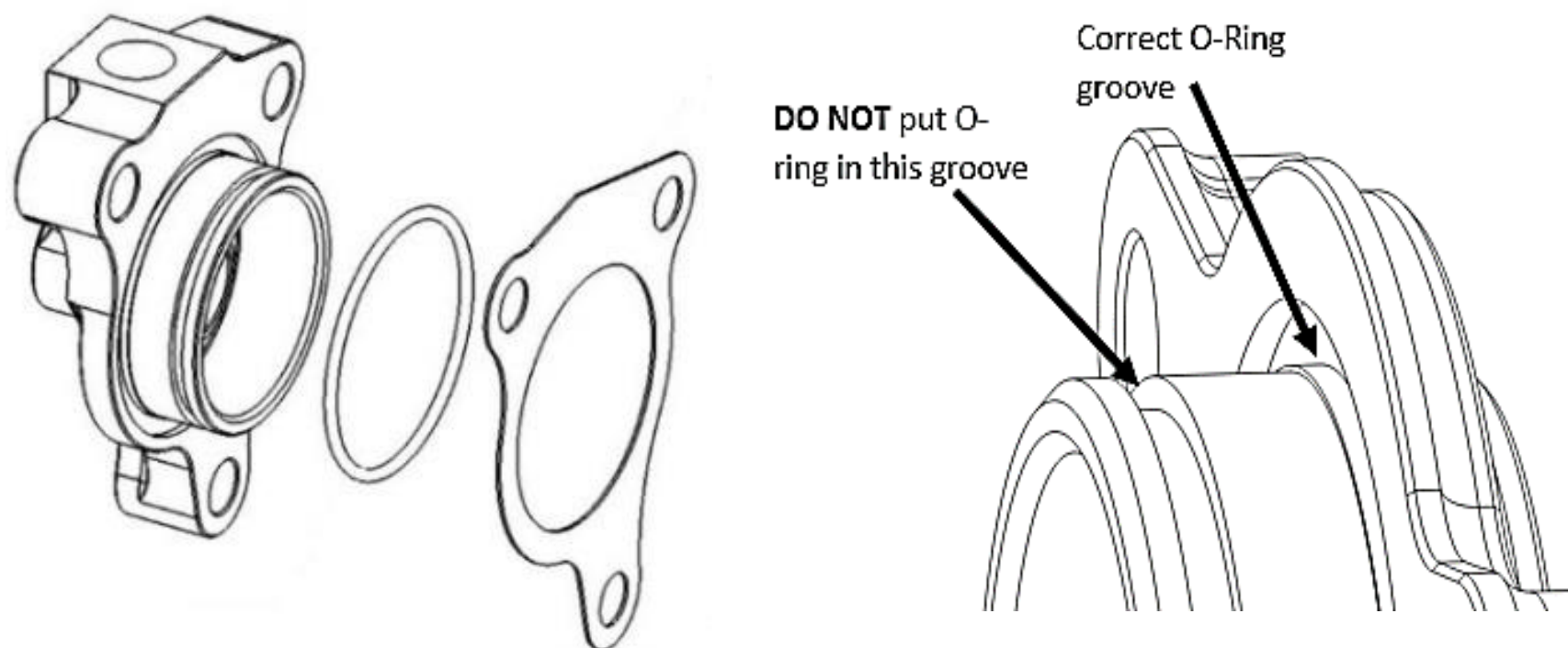

15. On the left side of the bike, while leaving the OE slave cylinder bolted on the engine, use a wrench to remove the banjo bolt from the OE slave cylinder.
16. Remove the clutch fluid line and the 2 crush washers from the OE slave cylinder.

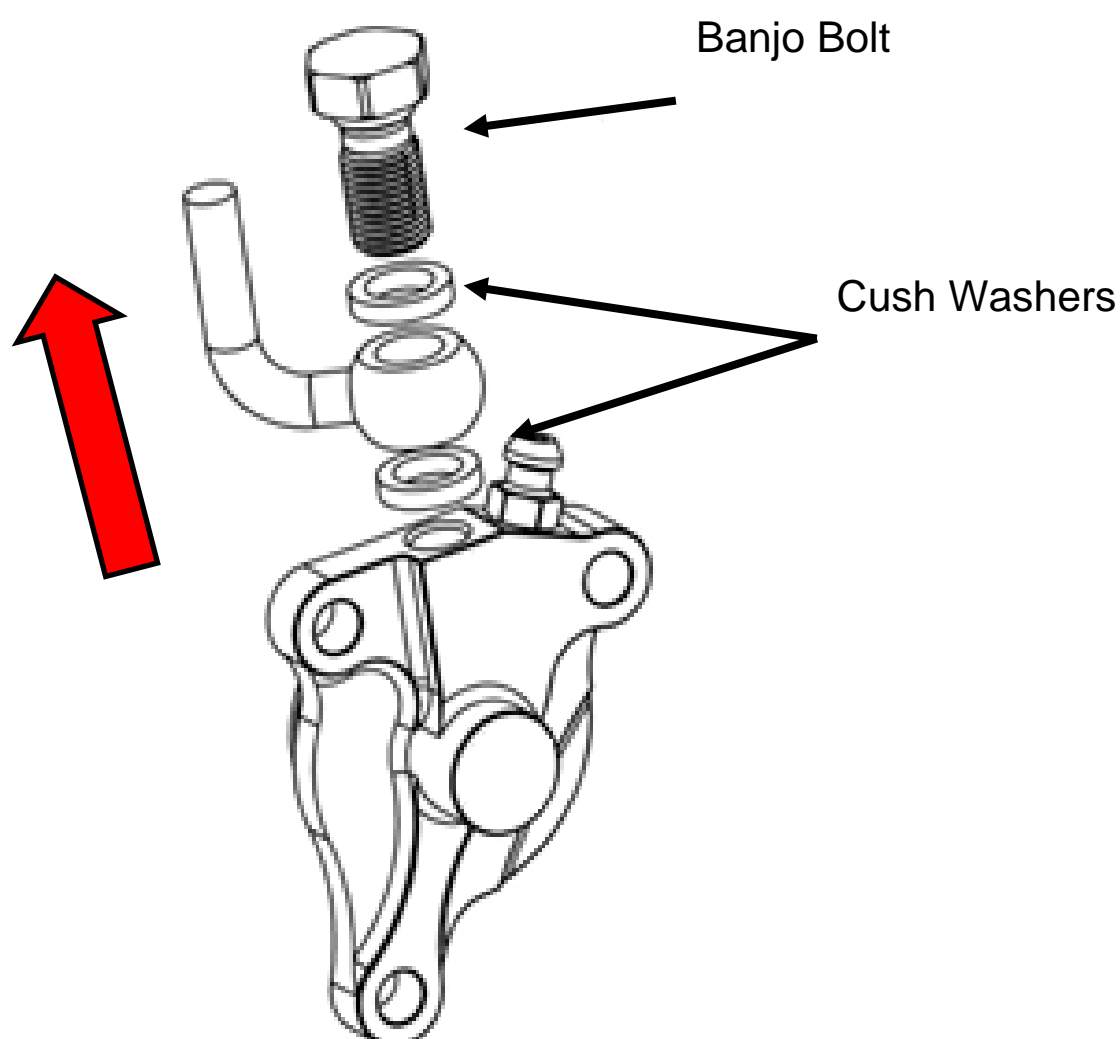

17. Set the OE crush washer aside. They will not be reused.

18. Attach the clutch fluid line to the Rekluse slave cylinder using the banjo bolt and the 2 new crush washers. Make sure the banjo fitting is between the crush washers.

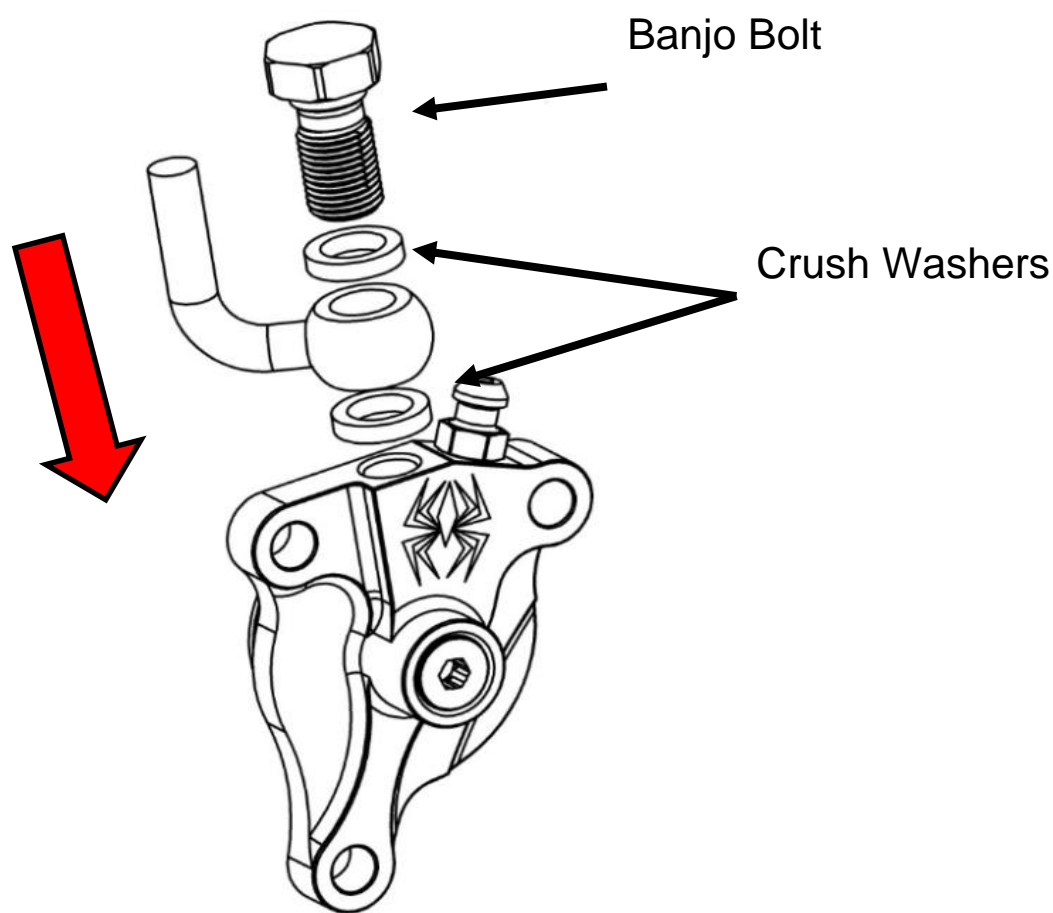

NOTICE

A quick transfer of the fluid line will result in less bleeding in the following steps.

19. Tighten the banjo bolt with your hand until snug. (You will torque it to spec once installed on the bike.)

20. With the clutch fluid line attached to the Rekluse slave cylinder, remove the OE slave cylinder from the engine. Keep the OE screws for reuse.

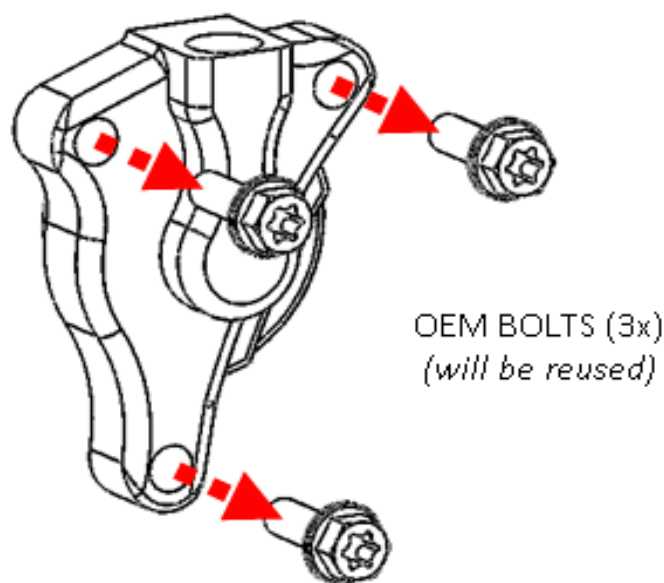

21. Mount the Rekluse slave cylinder to the engine using the OE screws until finger tight.

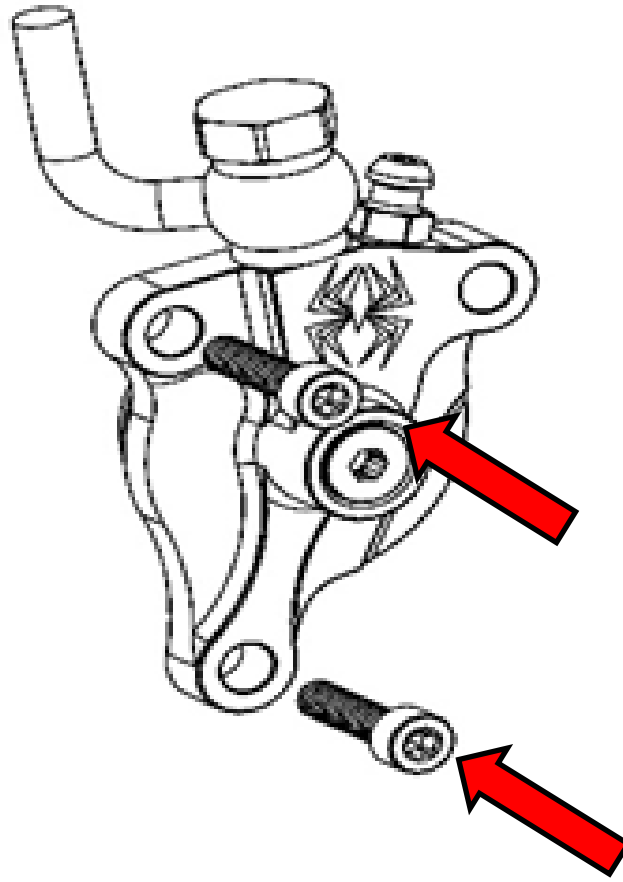

NOTICE

Some models have a piston diaphragm seal. DO NOT REUSE them if OE equipped.

OEM PISTON DIAPHRAM SEAL
(do not reuse)

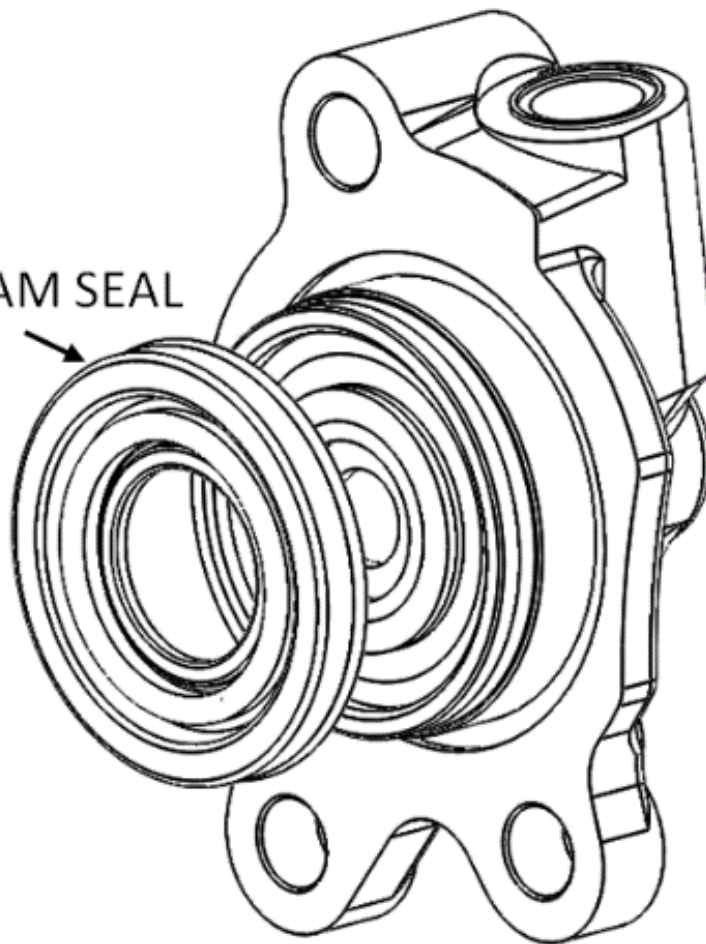

NOTICE

For GasGas and Beta motorcycles:

See the CLUTCH SETUP SHEET for additional instructions regarding the slave cylinder installation, as special requirements are necessary for your bike model.

22. Tighten all the slave cylinder screws to OE specification.

23. Torque the banjo bolt to 18 ft-lb (25 N-m).

24. Optional: If you purchased the Rekluse Slave Guard accessory, install it now using the instructions in the kit.

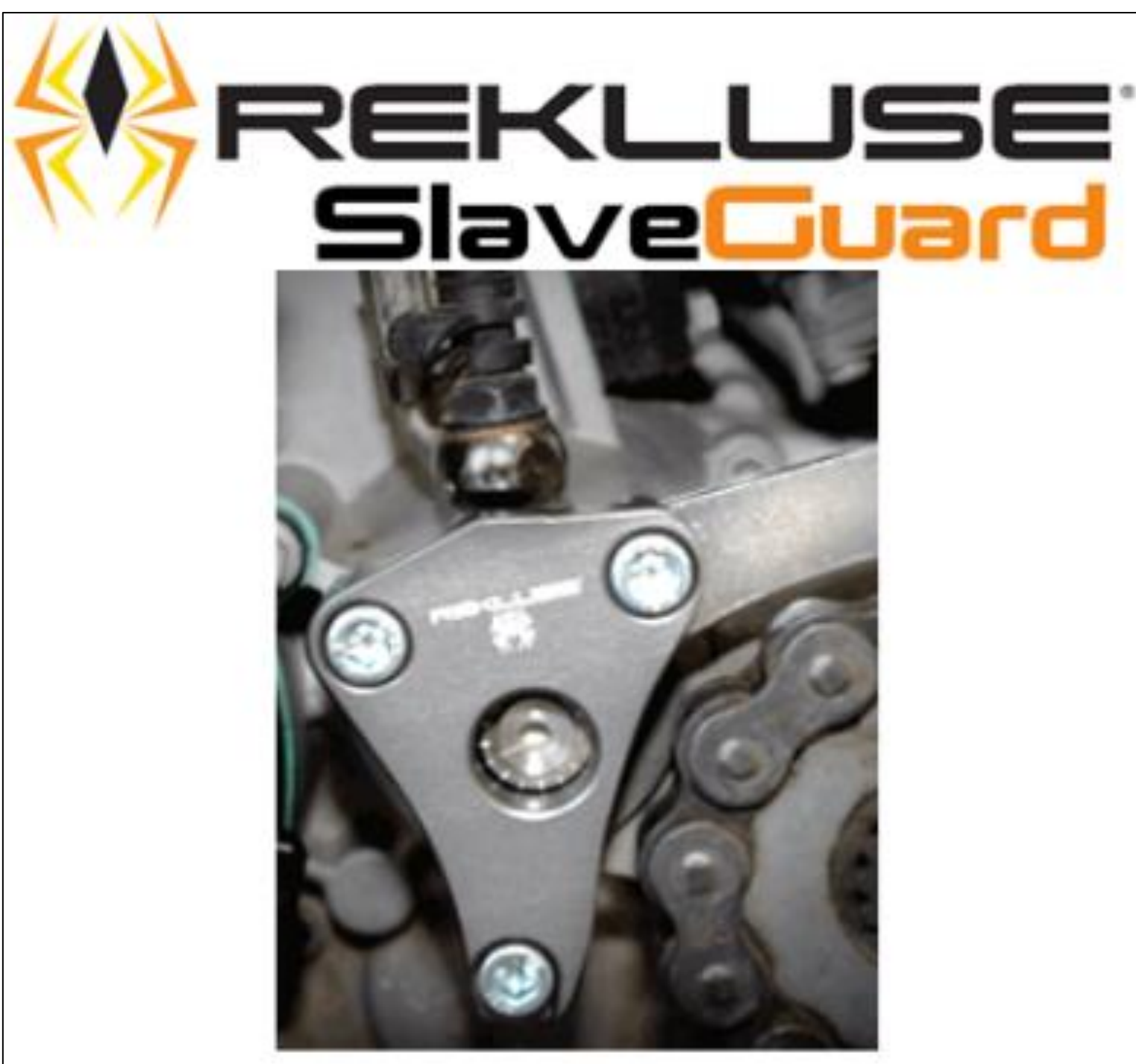

25. Remove the cap and bladder from the clutch master cylinder and top off the clutch fluid.

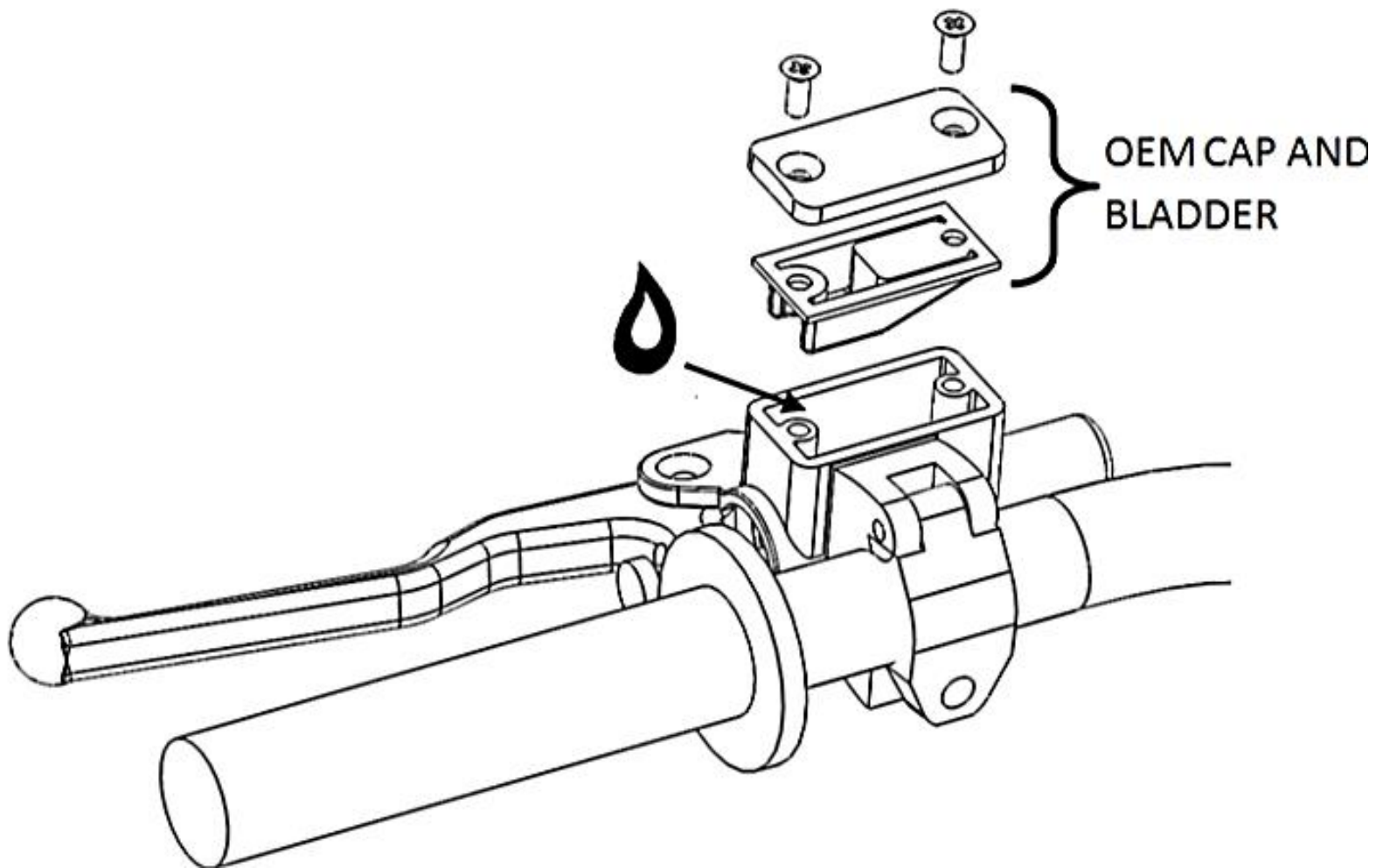

26. Attach the supplied bleed tube to the banjo bolt port and loop it into a suitable catch bottle.

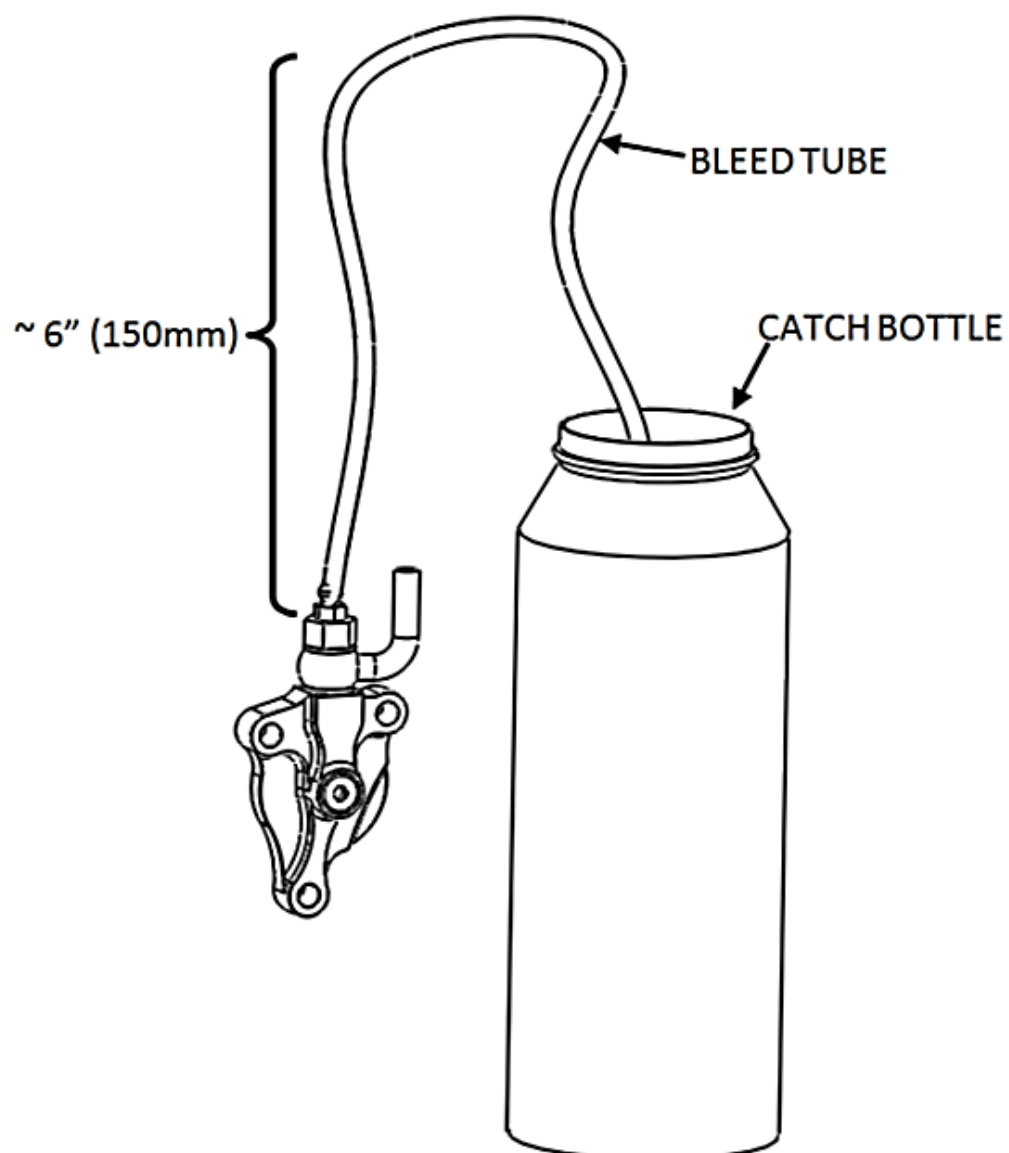

27. Pump the clutch lever 3-5 times then hold it against the bar/grip.

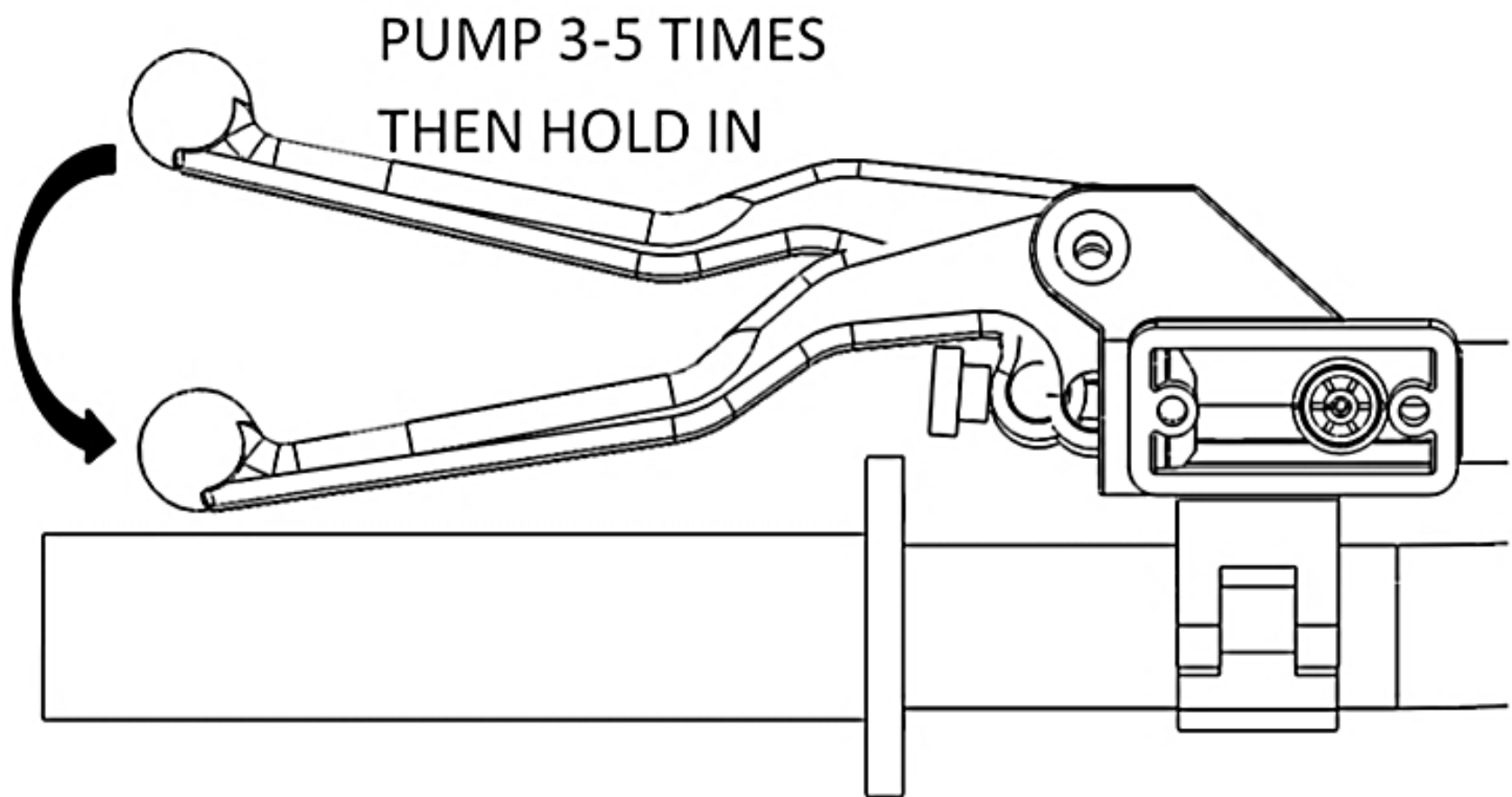

28. Using an 8mm wrench, open the bleed port. Air and fluid should come out of the bleed tube. Tighten the bleed port.

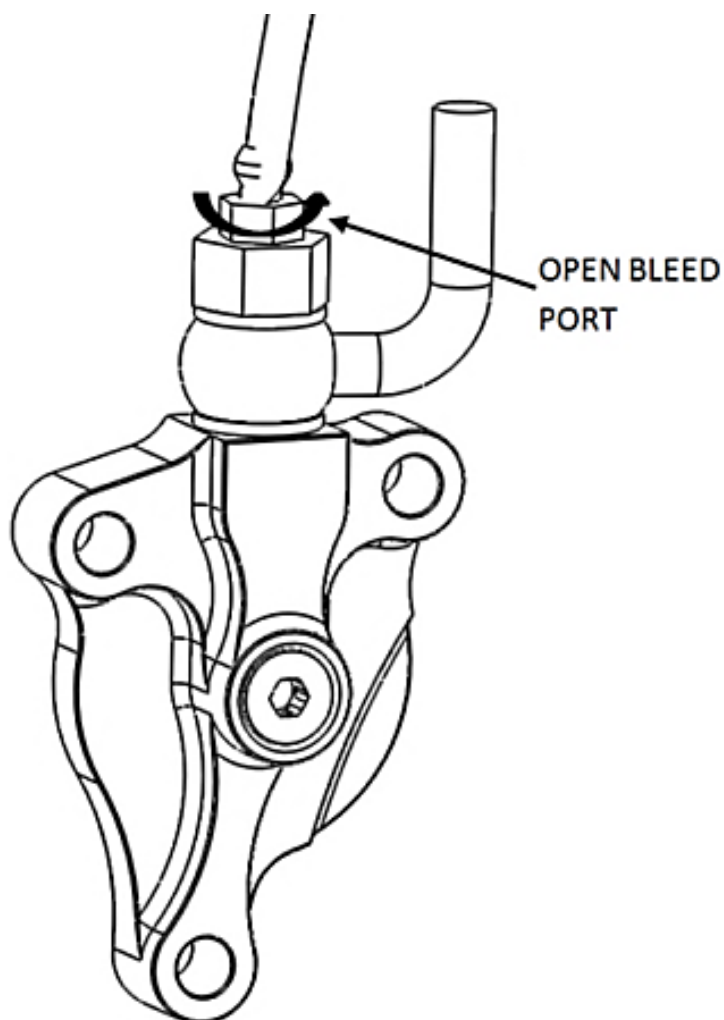

29. Slowly release the clutch lever and check the fluid level in the clutch master cylinder.

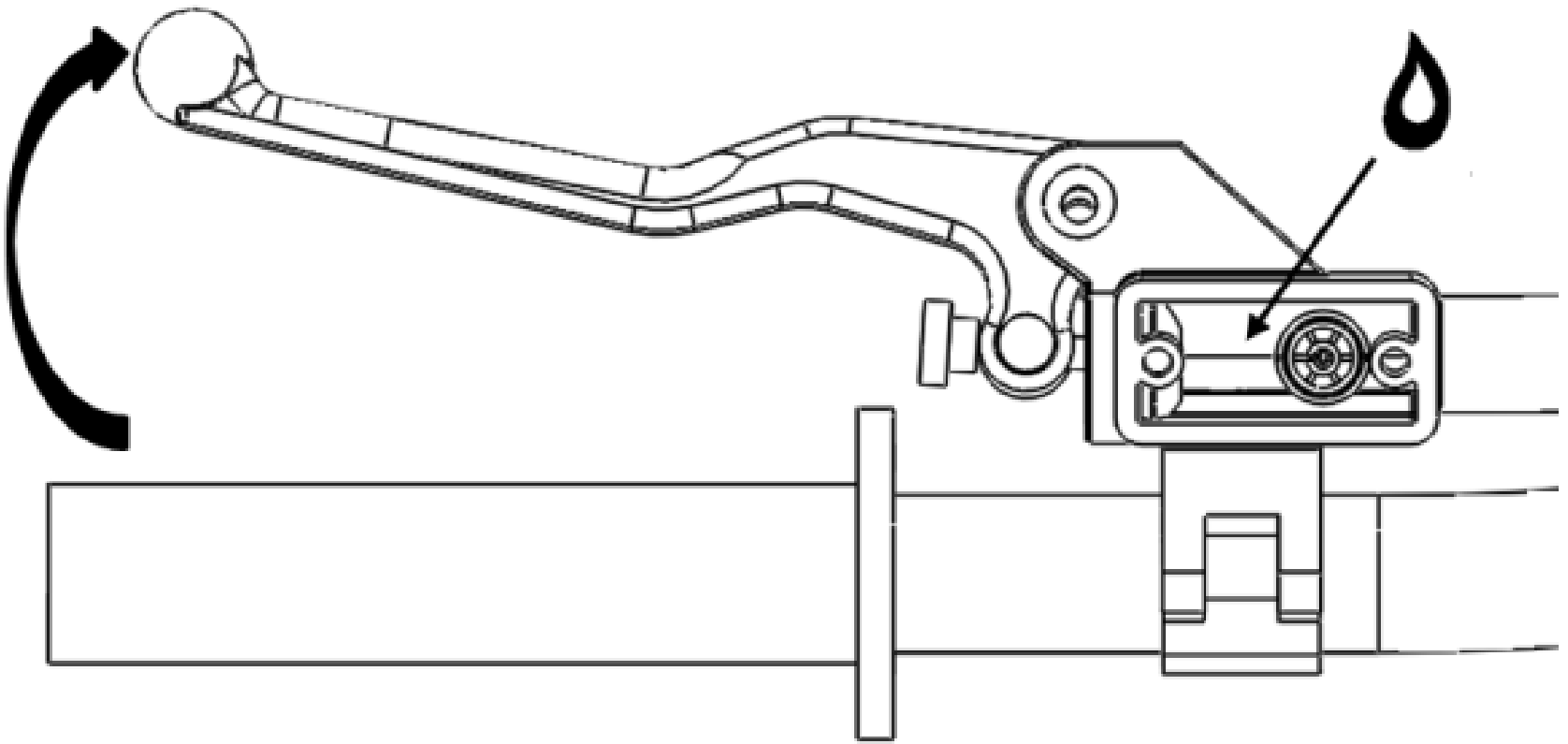

30. Repeat the previous 3 bleeding steps until air no longer comes out of the bleed port. Then, check that the clutch lever functions properly. Repeat the bleeding procedure if necessary.

31. Finally, remove the bleed tube and tighten the bleed port.

SETTING THE INSTALLED GAP

DEFINITION: “Installed Gap” is the separation in the clutch pack created by the adjustment of the Adjuster Screw in the Slave Cylinder. This gap is what allows the clutch to spin freely until the desired RPM is reached for engagement; it must be set correctly for optimal performance.

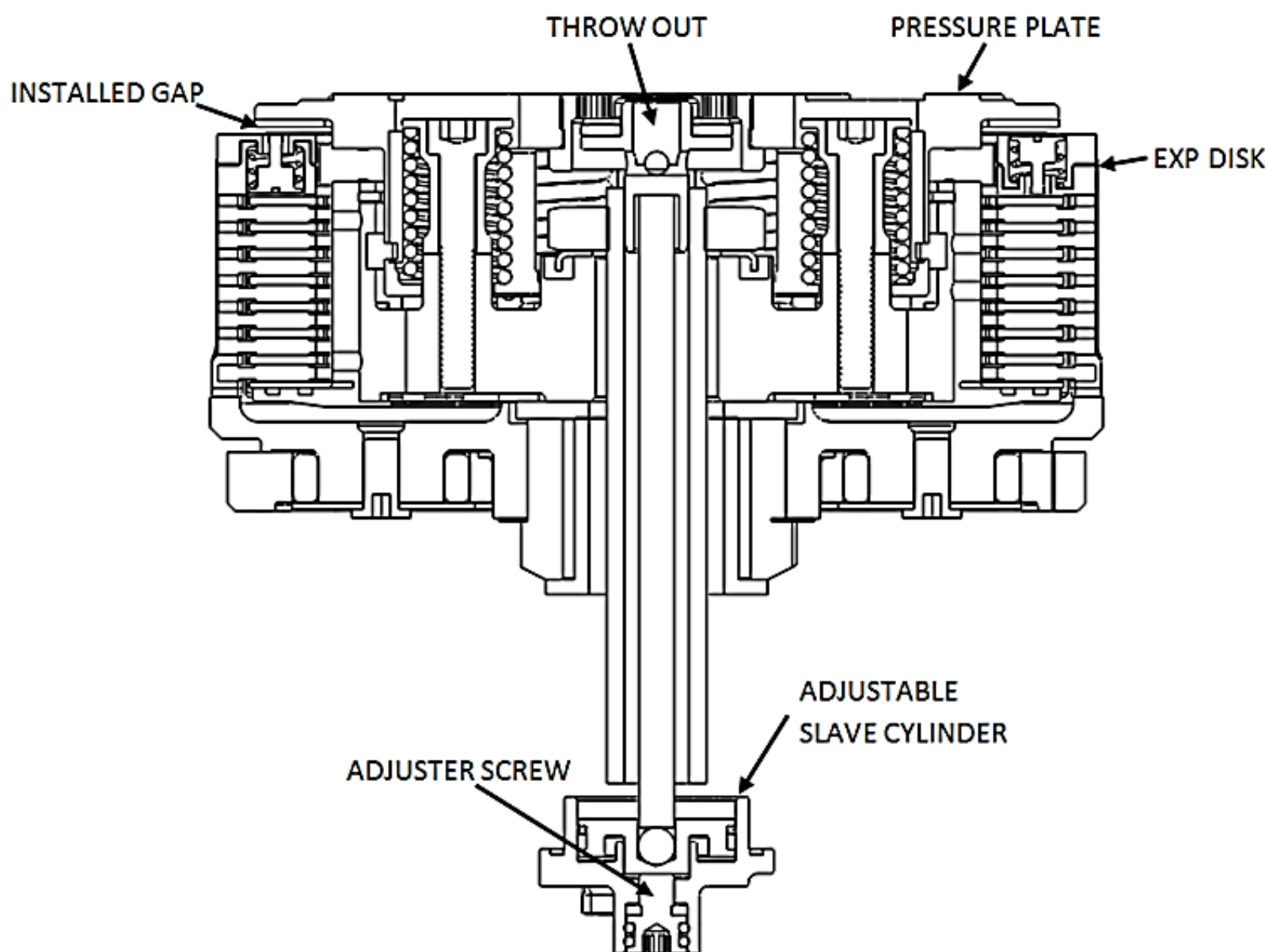

32. Using the long end of a 4mm Allen key, turn the adjuster screw clockwise until it stops under moderate pressure. You are trying to feel for the point at which the throwout will start to lift the pressure plate. This is the “starting point”.

NOTICE

It may take a few tries to find the point at which the system is bottomed out. You should feel a distinguishable change in turning effort at this point.

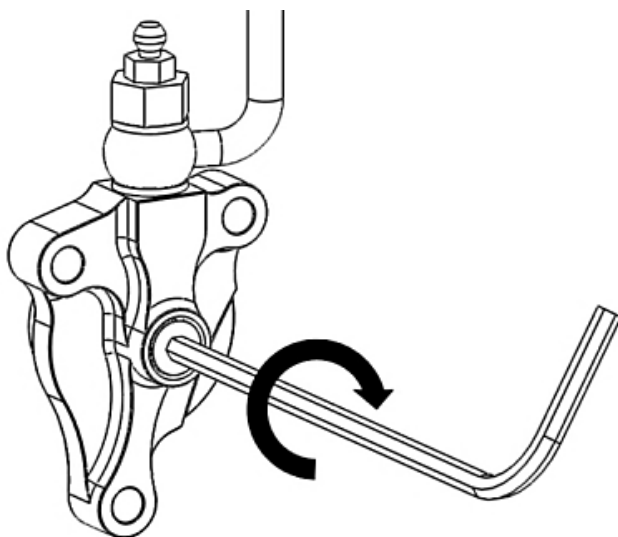

33. Once you have found the starting point, turn the adjuster clockwise 1 full turn plus 5 marks (or "1+5"). **This is NOT your final setting**, but it is a good reference point for using free play gain to find the correct setting.

34. Top off your master cylinder fluid level, and re-install the master cylinder cap.



T20

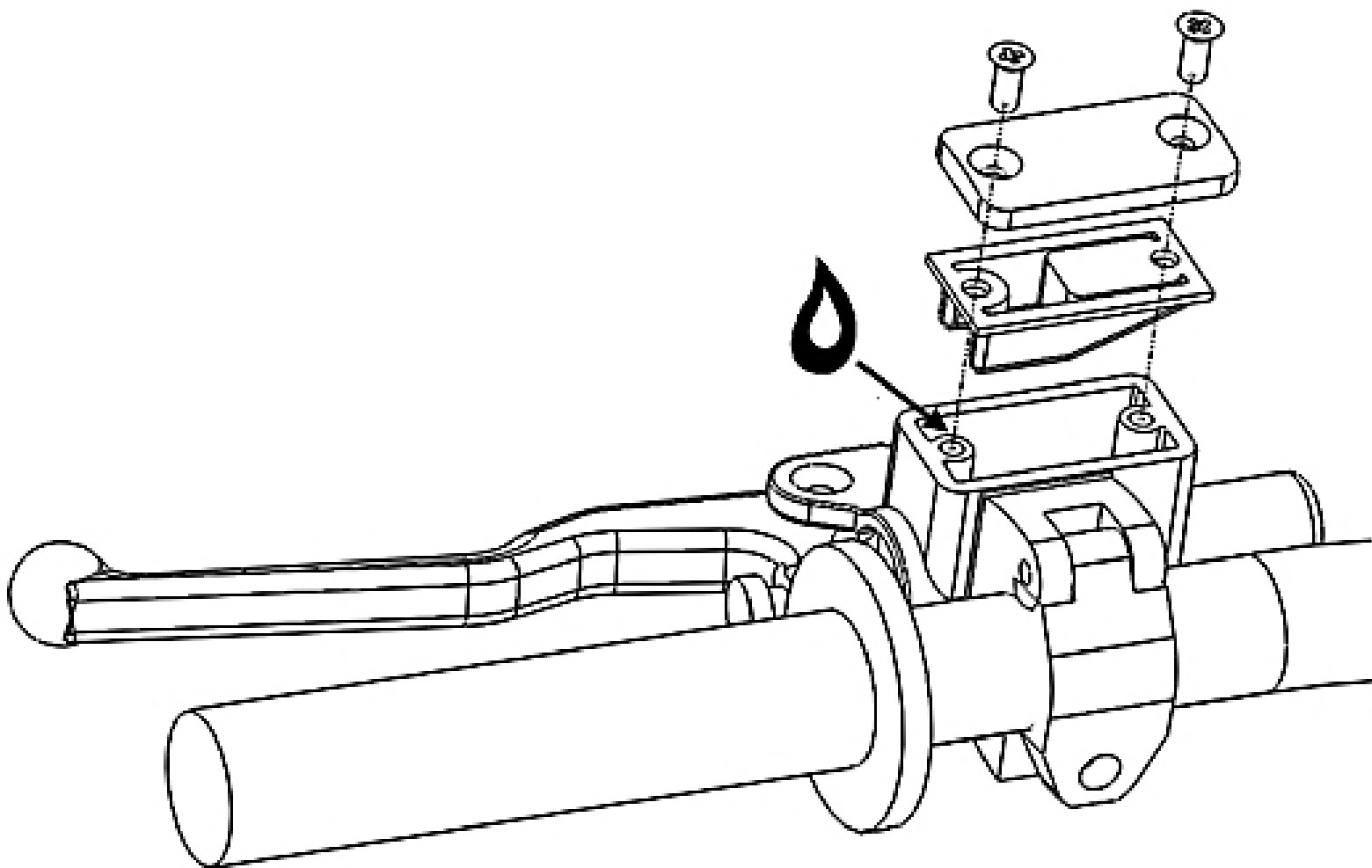

CHECKING FREE PLAY GAIN

⚠ WARNING

Always make sure that the bike is in NEUTRAL before checking Free Play Gain. Failure to do so may result in the bike lurching forward, and loss of control and/or injury may result.

NOTICE

Before performing this step, please visit our website at rekluse.com/support to view the TECH VIDEO entitled “How to Check Free Play Gain”.

“Lever Free Play” is essentially the “slack” in the clutch lever before it starts actuating the clutch. Applying a light finger pressure will take up this slack.



“**Free Play Gain**” is the increase of lever free play as the auto-clutch engages. This happens when the RPM increase from idle through around 5000 RPM. Free Play Gain is caused by the expansion of the EXP disk which lifts the pressure plate away from the throwout assembly.

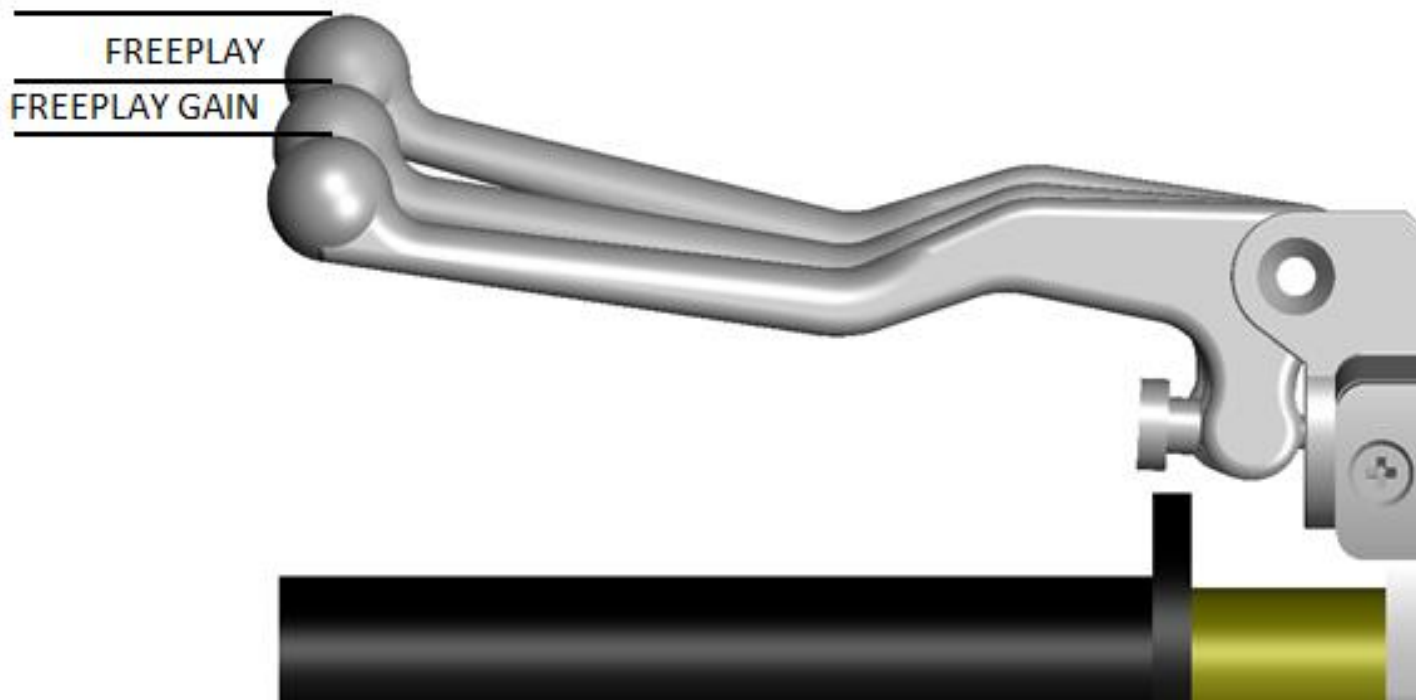

Optimal Free Play Gain yields **1/8-1/4” (3mm-6mm)** of clutch lever movement, measured at the end of the lever. This measurement at the lever correlates to achieving the ideal installed gap.

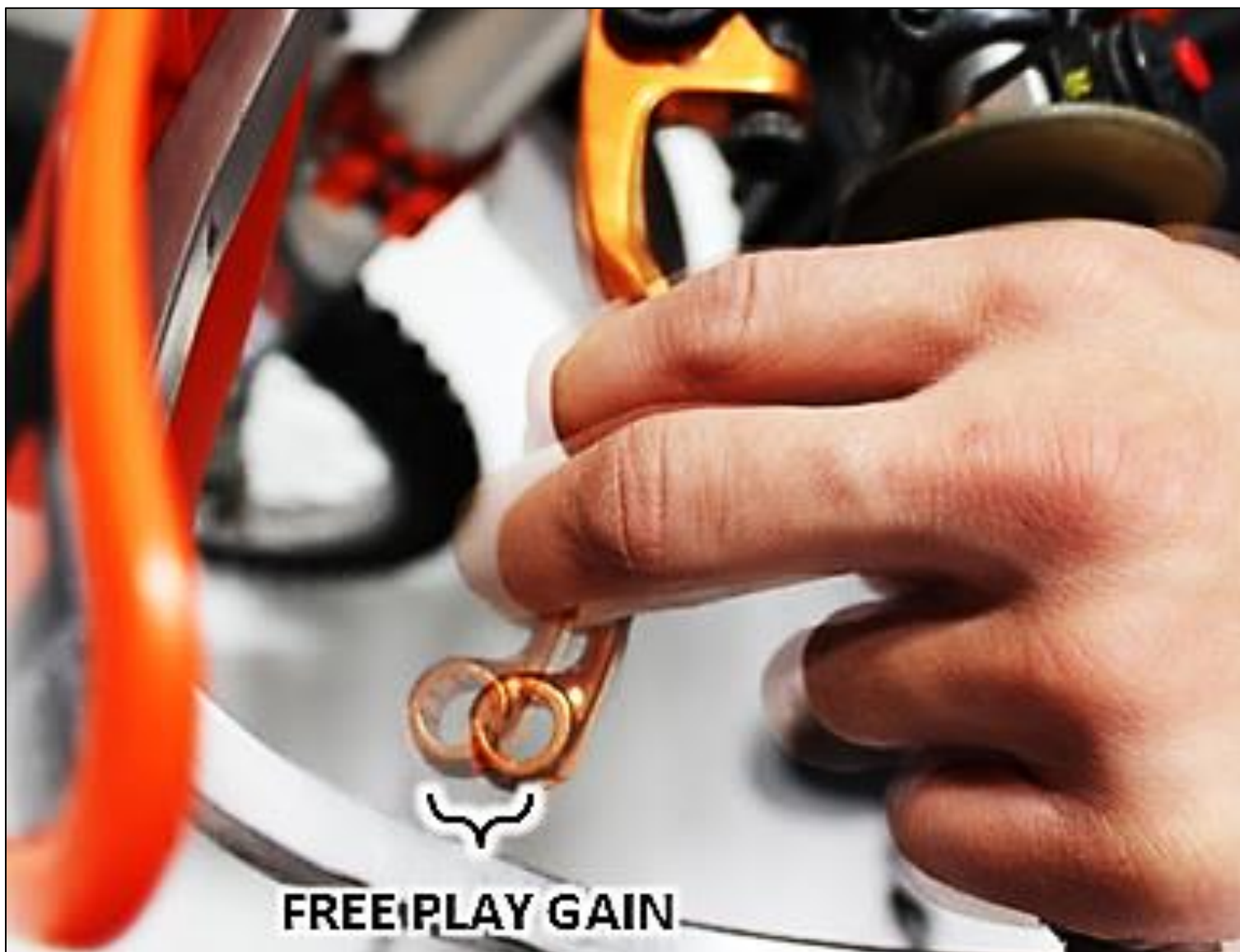

The following steps explain two ways to check Free Play Gain. One will use the rubber band that has been included in the clutch kit and one explains using your hand, which you will perform before every ride.

Place the bike in neutral, start the engine and let it warm up for 2-3 minutes.

RUBBER BAND METHOD

35. We recommend that you use this method to find your initial “Free Play Gain” so you can see what it is. We recommend also checking it by hand as explained in the next step so you can check free play gain both ways.

Wrap the included rubber band around the outer end of the handlebar grip and attach to the ball end of the clutch lever. See the following three photos for an example.



HAND METHOD

36. Free play gain can also be checked by using your hand and holding light pressure on the lever. With the bike at idle, pull on the clutch lever lightly with a single finger so the lever free play is taken up, but the clutch is not disengaged. While continuing to apply light pressure, rev the engine to at least 5000 RPM. **The clutch lever should move in 1/8 - 1/4” (3mm – 6mm) under your finger pressure as you rev the engine.**

NOTICE

If you are not getting the correct lever movement, see the “Free Play Gain Troubleshooting Guide” on the next page.

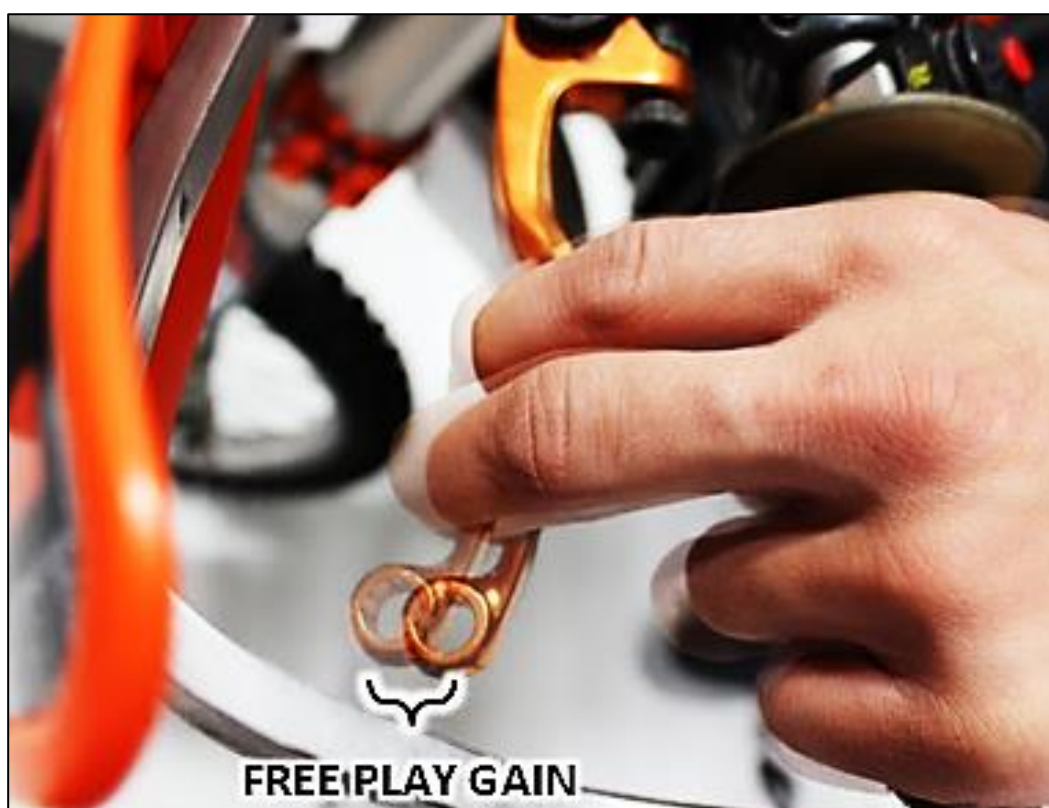

Free Play Gain Troubleshooting

Each adjustment should be done in small increments - one tick mark at a time. After each adjustment, repeat the rev-cycle until optimal free play gain is achieved.

Symptom:

- Clutch lever moves in too far (too much free play gain)
- Clutch has excessive drag
- It is difficult to fully override the clutch with the lever

Answer: Installed Gap is too small

Solution: Turn the Adjuster Screw inwardly (clockwise) to increase the Installed Gap.

Symptom:

- Clutch lever does not move enough or does not move at all (too little free play gain)
- Clutch is slipping

Answer: Installed Gap is too large

Solution: Turn the Adjuster Screw outwardly (counter-clockwise) to reduce the Installed Gap. It may be helpful to re-find the starting point.

BREAK-IN PROCEDURE

After desired free play gain is achieved, it is time to break in the EXP disk.

37. REV CYCLES: With the transmission in neutral and no pressure on the clutch lever, rev the engine to about 5000 rpm and let it return to idle. Perform 10 rev cycles.

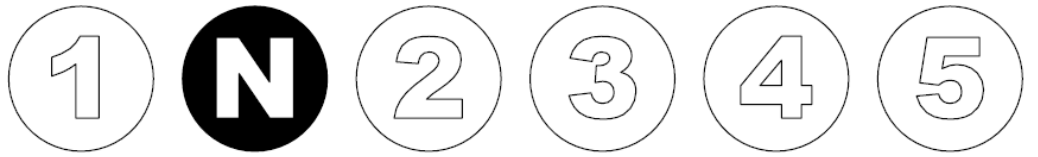

38. ROLL-ON STARTS: Pull in the clutch lever and click the transmission into first gear. Slowly release the clutch lever. The engine should stay running and the bike should have minimal forward creep. If the engine wants to stall or the creep is excessive, the idle may be too high or the installed gap may be too small. Make necessary adjustments before proceeding.

a. FIRST GEAR: Slowly roll on the throttle to begin moving. Accelerate to around 5000 rpm and come to a stop. Perform 10 first gear roll-on starts.

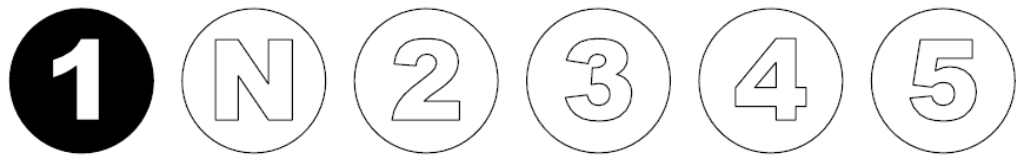

b. SECOND GEAR: Click the transmission into second gear and perform 10 roll-on starts.



c. Re-check free play gain and adjust if necessary.

39. **4 strokes only:** It is normal for some clutch debris to be produced during break in. Following break-in, remove the OE oil filter and inspect for clutch debris. Clean or replace if necessary.

⚠ WARNING

Failure to inspect the oil screen and remove any clutch debris could cause motor damage. This can result in loss of control and/or injury may result.

IMPORTANT: Check Free Play Gain before every ride.

NOTICE

Do not perform 3rd gear starts with this product. 3rd gear starts over time will burn up the clutch and decrease the performance of this product in a short amount of time.

⚠ WARNING

DO NOT RIDE WITHOUT SUFFICIENT FREE PLAY GAIN!

Checking free play gain is easy and takes less than a minute to perform. For optimum performance and longevity, check freeplay gain when the bike is warm at the start of every ride.

MAINTENANCE

Maintenance Protocol (see setup sheet)	Maintenance Interval
Check and verify Free Play Gain	Every ride
Inspect all clutch parts for excessive wear or heat. Replace as needed.	Refer to service manual

OPTIMIZING EXP ENGAGEMENT

For best performance, engine idle speed should be **slightly** adjusted to match the EXP engagement setting.

NOTICE

Make sure Free Play Gain is optimal before adjusting idle speed.

With correct Free Play Gain and the bike in gear, the bike should move forward under slight opening of the throttle. If not, one of the following symptoms is likely:

- HIGH IDLE – the bike moves forward with the throttle fully closed. Solution: reduce idle RPM.
- LOW IDLE – the bike moves forward after engine RPM becomes noticeably higher than idle RPM. Solution: increase idle RPM.

NOTICE

If a slight idle adjustment does not alleviate the problem refer to the EXP setup sheet for an additional tuning and EXP spring setting guide.

Clutch Squeal and Chatter

Although it is harmless, some bike models may have “squeal” or “chatter” coming from the clutch at low RPM as it engages. Clutch squeal is caused by the clutch components vibrating as the clutch engages and can become more audible as the clutch gets hot. For bike models that tend to have clutch squeal or chatter here are some recommendations to reduce or eliminate it:

- Oil: Rekluse recommends that you have fresh, clean JASO-MA or JASO-MA2 rated oil for best clutch performance. Dirty or old oil can make the clutch more likely to squeal or chatter.

BUMP-STARTING INSTRUCTIONS

If your vehicle needs to be bump-started due to a dead battery or any other reason, follow the steps below to quickly bump-start your vehicle.

1. Use your adjustable slave cylinder to collapse the gap until no resistance is felt.
2. Bump start the vehicle. The clutch will function like a manual clutch at this point, but the clutch will not be fully over-rideable at high RPMs.
3. Once the vehicle is started, readjust the gap to set the installed gap.

NEED ADDITIONAL HELP?

Website

www.rekluse.com/support

Frequently asked questions

www.rekluse.com/faq

Support Videos

www.rekluse.com/support/videos

Phone

(208) 426-0659

Technical Support

Contact Technical Support for questions related to product installation, tuning, and performance.

Hours:

Monday thru Friday: 8:00 a.m. - 5:00 p.m.

Mountain Time zone

Email: tech@rekluse.com

Customer Service

Contact Customer Service for additional product information, orders, and returns.

Hours:

Monday thru Friday: 8:00 a.m. - 5:00 p.m.

Mountain Time zone

Email: customerservice@rekluse.com

REKLUSE®



©2017 Rekluse Motor Sports
Rekluse Motor Sports, Inc.
208-426-0659

customerservice@rekluse.com

DOC ID 191-6302
REVISION 112917